



# **The Surface Properties of Asteroids**

**Dan Britt**

**University of Central Florida**

**Center for Lunar and Asteroid Surface Science (CLASS)**

# Regolith

- **Greek *rhegos* (blanket) + lithos (stone) the mantle of fragmental and unconsolidated rock material that nearly everywhere overlies bedrock.**
  - This includes terrestrial soils.
  - On rocky objects, particularly asteroids and moons, what you see on the surface is regolith.
  - It will be different than lunar regolith



# How do We Know About Asteroid Regoliths?

- Meteorites: Samples of regoliths
- Spacecraft and Telescopes: Images of regolith structure and telescopic data.
- Theory: Informs on structures that we cannot see

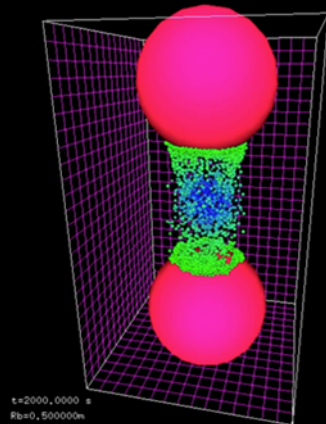
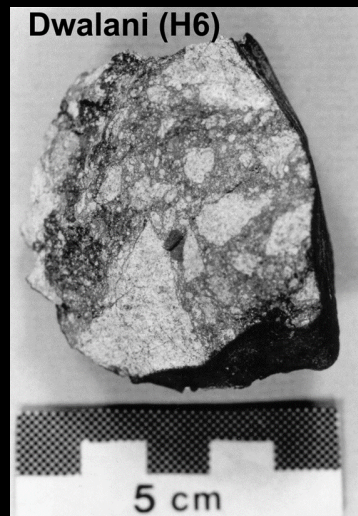

# Regolith Meteorites?

- **About 12% of Ordinary Chondrite falls have solar wind implanted gases.**
  - They are samples of the regolith!
  - Some Carbonaceous Chondrites are all regolith (like CIs)
- **Characteristics of asteroid regoliths from meteorites**
  - Fine grain with cobbles and fragments
  - Shock darkened
  - Comminution (the dark fined grained stuff is derived from local materials)
  - Space Weathering

Dwalani (H6)

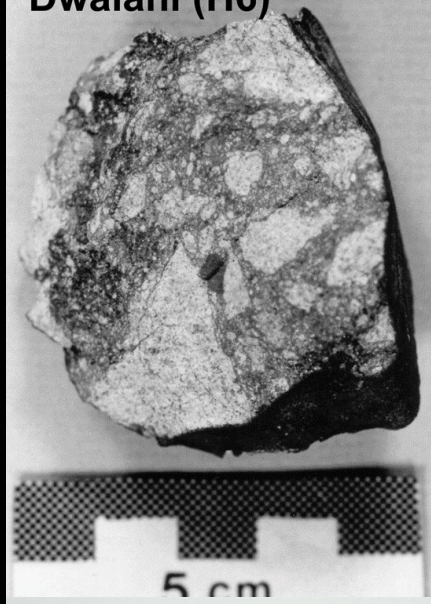

# Space Weathering

- **Alterations suffered by solid materials when directly exposed to the space environment.**
  - **Shock and heating from impacts**
  - **Chemical disequilibria from vacuum and reducing conditions**
  - **Comminution, Agglutination**
  - **Crystal damage and spallation from cosmic rays**
  - **Irradiation, solar-wind implantation, sputtering, charging**

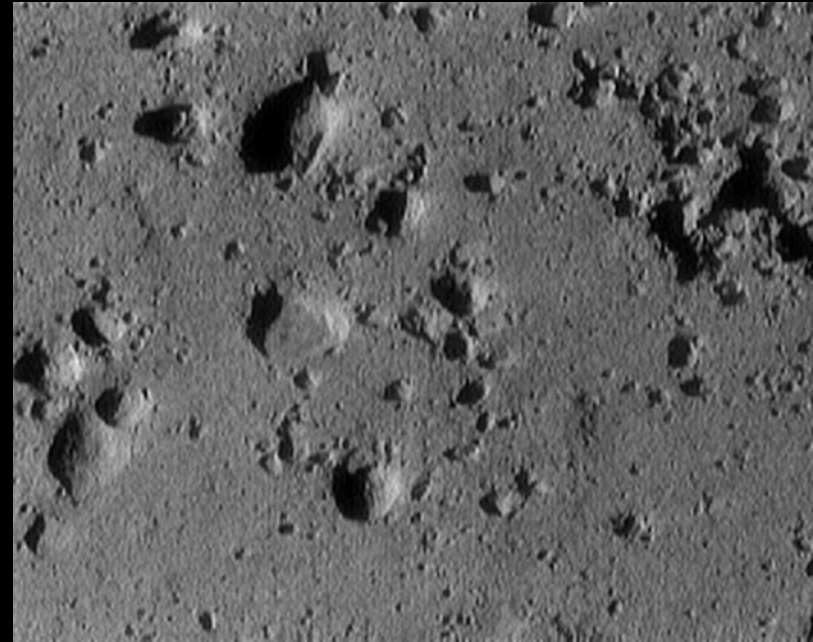

# Regolith Processes: Comminution

- **Comminution: breaking of rocks and minerals into smaller particles**
  - Impacts at all scales grind down particle size.
  - Major impacts produce ejecta blocks
  - Micrometeorites grind down gravel and blocks to dust (remember they impact with an order of magnitude more energy than a bullet)

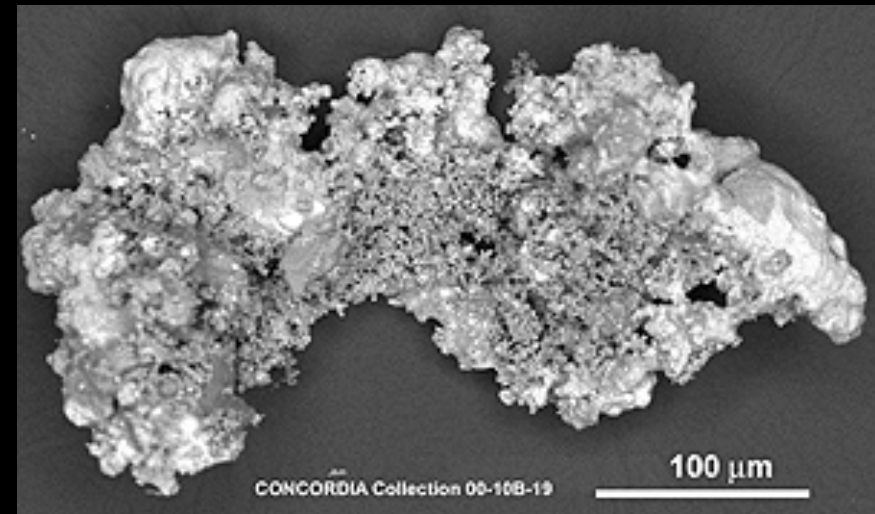
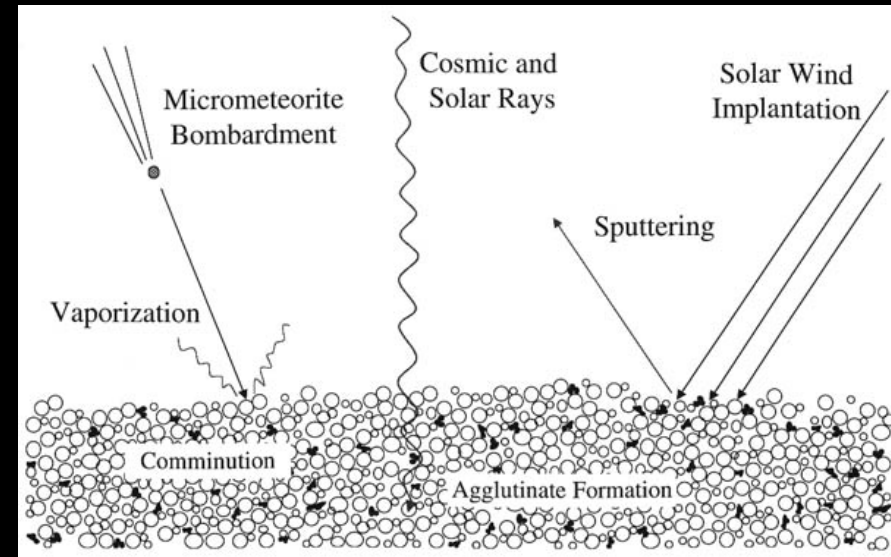

# Regolith Processes: Agglutination

- **Agglutination:** welding of mineral and rock fragments together by micrometeorite-impact-produced glass.
- **High-velocity impacts** produce enough heating in Lunar soils to melt material and weld fragments.
- This process is limited to the Moon (and probably Mercury) since impact speeds need to be  $\sim 10$  km/s
- **Agglutinates** are NOT found in meteorites..... Average impact velocities in the asteroid belt are  $\sim 5$  km/s. Too low to produce melting and agglutinates.

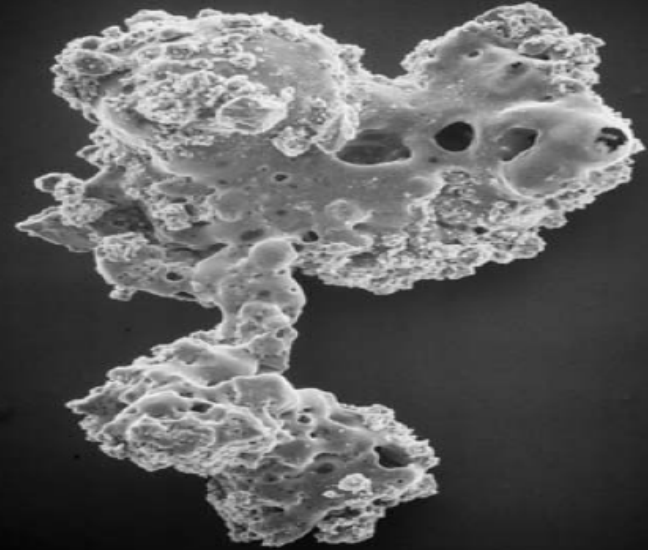

79µ 019

25kV .125kX

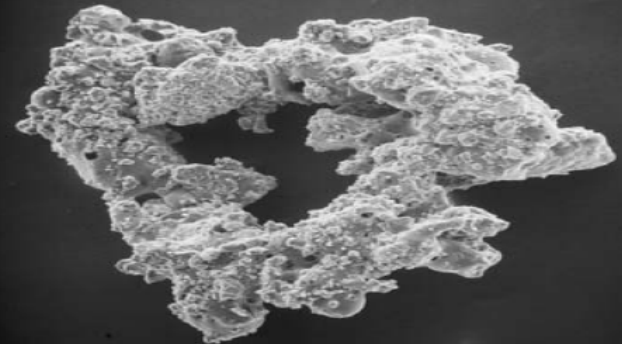

80µ 024

20kV .125kX

# Regolith Processes: Agglutination

- **Agglutination works against comminution since it joins small particles to form bigger particles.**
- **This is important on the Moon, but impact velocities (and thus energies) are much lower on asteroids so welding will be less important.**

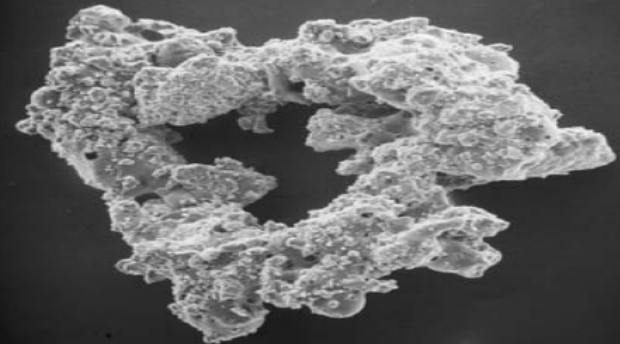
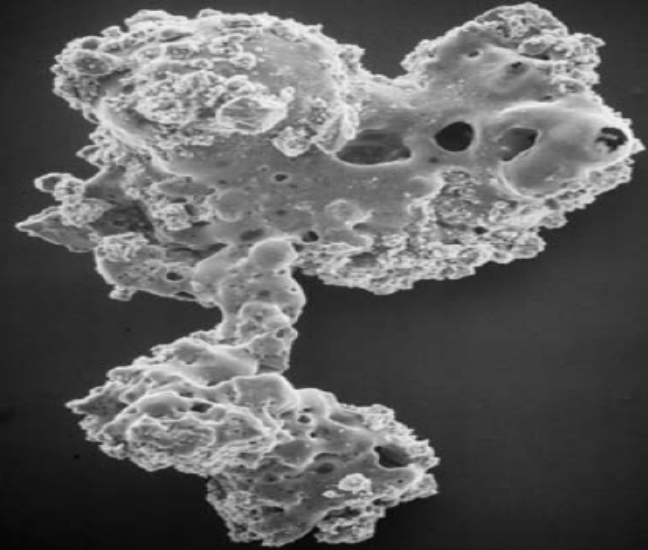



# **Regolith Processes: Solar Wind Effects**

- **Spallation:** formation of elements as a result of cosmic ray impacts that cause protons and neutrons to spall off.
- **Implantation:** See next slide
- **Vaporization:** See next slide
- **Sputtering:** atoms are ejected from a solid target material due to bombardment of the target by energetic particles. The sputtered atoms mostly recondense on grain surfaces.
- **Charging:** Solar ultraviolet and X-ray radiation are energetic enough to knock electrons out of the lunar soil. Positive charges build up until the tiniest particles of lunar dust are repelled and lofted anywhere from m's to km's high. Eventually they fall back toward the surface where the process is repeated. On the night side, the dust is negatively charged by electrons in the solar wind.

# Regolith Processes: Solar Wind Implantation and Vaporization

- The elements making up the solar wind are implanted onto the surfaces and shallow interiors of the regolith.
  - The wind is mostly H and He, so these dominate
- The buildup of solar wind H can change the chemistry of the regolith, creating reducing conditions.
- When the regolith is briefly heated by impacts, the implanted H drives reduction reactions.
  - Iron-rich silicates (olivine and pyroxene) are converted to reduced iron and iron-poor enstatite.
  - This produces particles of submicron Fe which when suspended in agglutinate glass is a powerful reddening agent.
- Vaporization: Low-temperature phases can be vaporized during impact and will recondense on surfaces

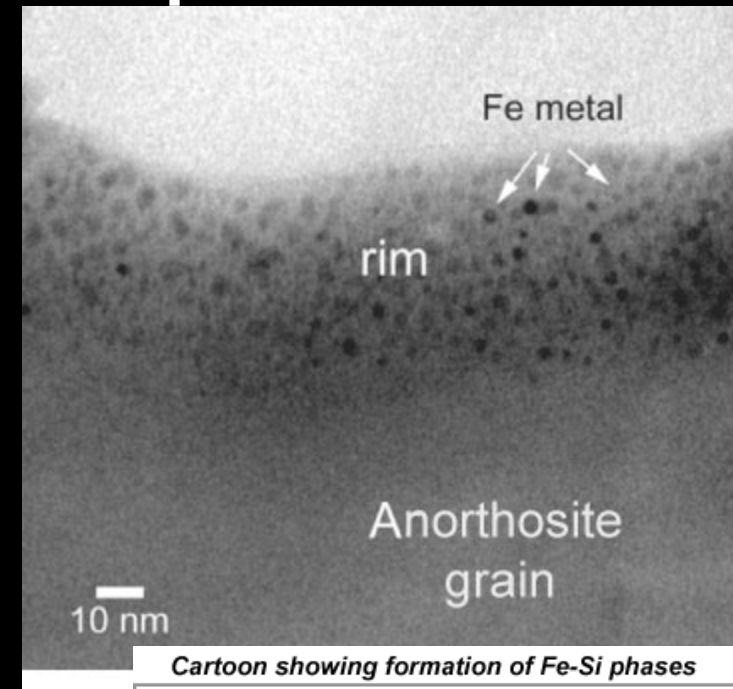

Cartoon showing formation of Fe-Si phases

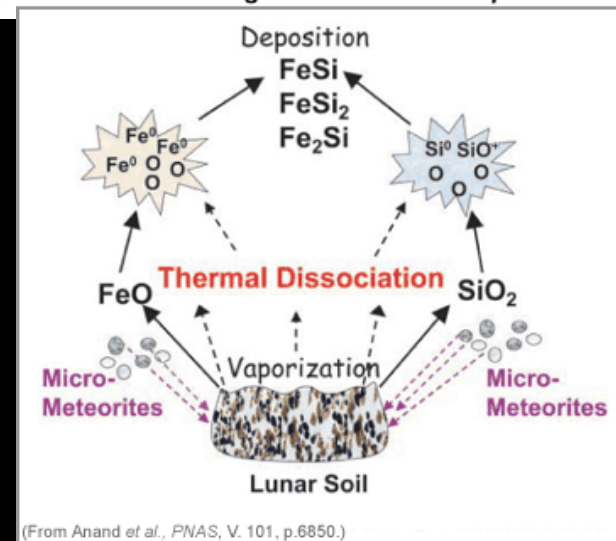

# Space Weathering

- **This term covers the alterations suffered by solid materials when exposed to the space environment.**
  - **Crystal damage and spallation from cosmic rays**
  - **Irradiation, implantation, and sputtering from solar wind particles**
  - **Bombardment and vaporization by different sizes of meteorites and micrometeorites.**
  - **Or almost any regolith process.....**
- **The effects of space weathering depend on the chemistry of the target material. For lunar materials and ordinary chondrites, one effect is to darken the material and reddening the spectra.**

# Our “Type Section” for Space Weathering has been the Moon

- Lunar weathering generates nano-phase Fe (amongst other things) on the grain surfaces and in glassy rims.
- This is **EXTREMELY** optically active and produces the characteristic lunar “red slope” in the visible and near-IR spectra.
- Another effect is the darkening of the reflectance and attenuation of the absorption bands.

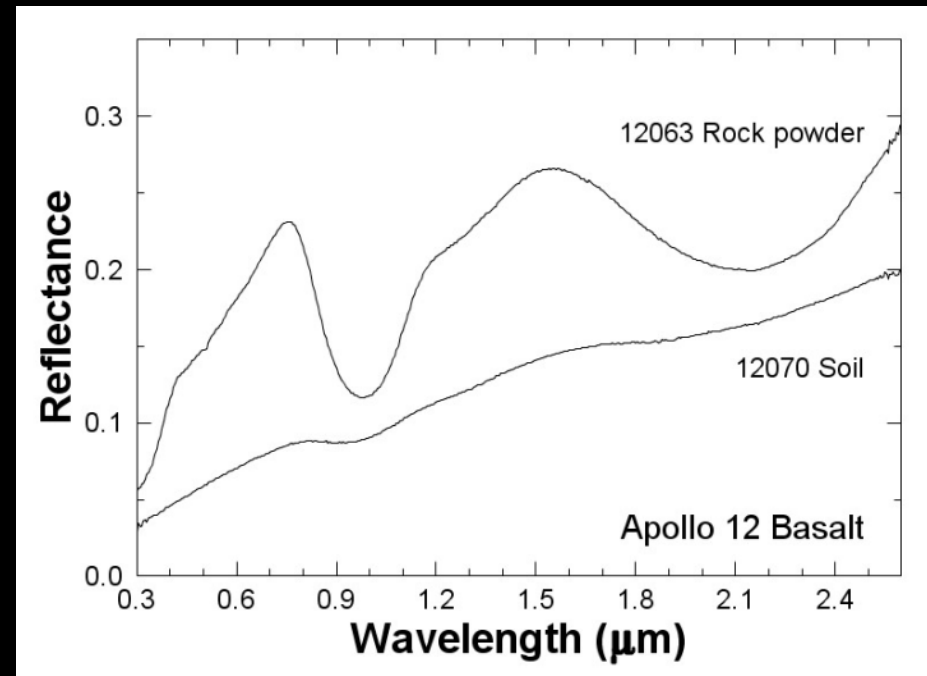

# Space Weathering on Asteroids

- But the weathering products depend on the chemistry of the base material and the energy input.
- The lunar case has a limited mineralogy and a much higher energy flux than asteroids, so more extreme alteration (reddening) results.
- You get reddening and band attenuation on some asteroids, just not as much.
- AND, asteroid chemistry is much more variable, so weathering products will be much more variable.

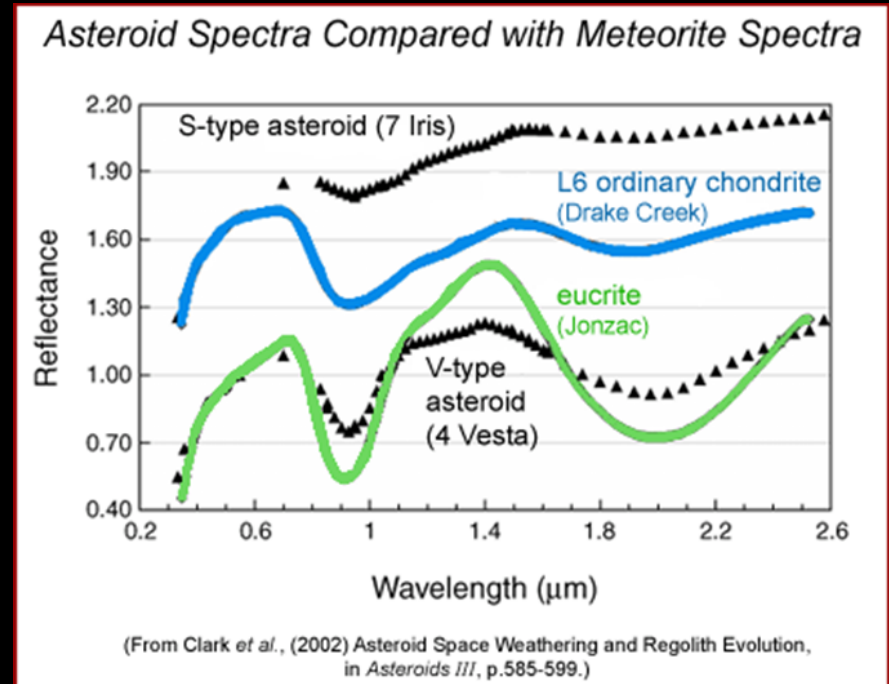

# Asteroid Regolith Soil Structure

- For small asteroids comminution has a twist
  - Low gravity, low escape velocity
  - Much higher thermal inertia
  - Solar wind interactions
- As asteroids get smaller
  - Low gravity allows progressively larger ejecta debris to escape
  - Smaller asteroids have courser regolith soil
  - The larger materials are preferentially retained potentially creating a lag deposit
  - Analog is deflation and “desert pavement”

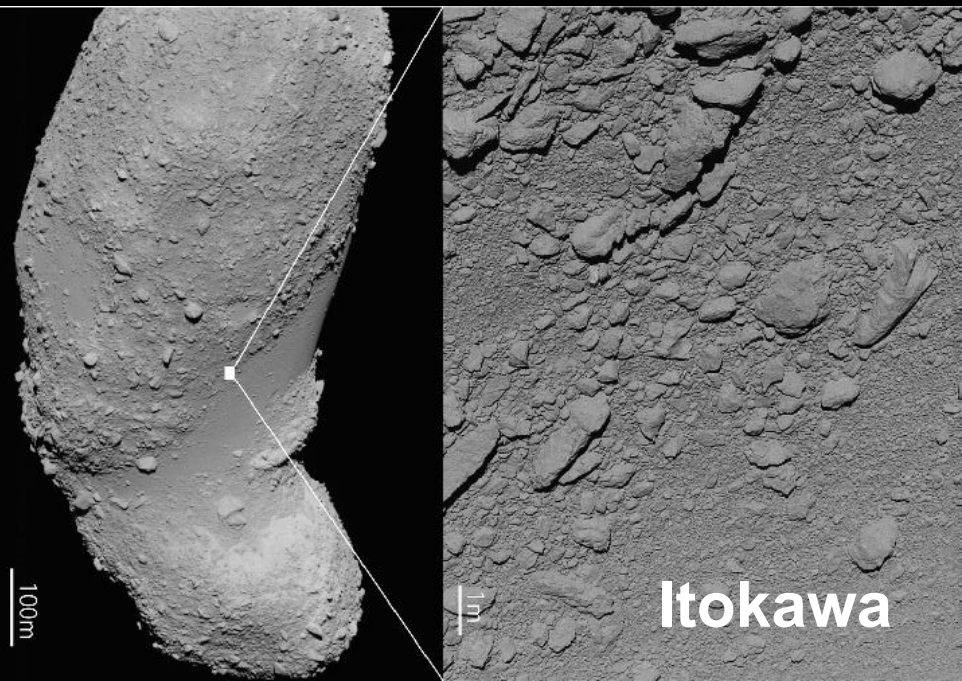
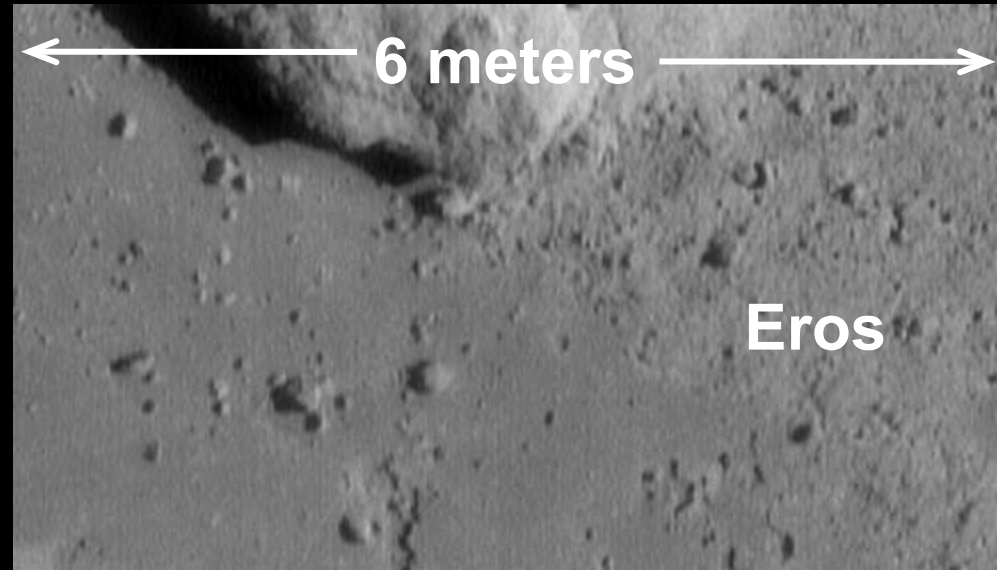

# Deflation and Lag Surfaces

- If fine particles are being transported, the surface erodes or “deflates”.
  - In deserts what remains are particle sizes too large/heavy to be lost to wind erosion.
  - On small asteroids an analogous process occurs with impact ejection and the solar wind.
- The remaining “lag” armors the surface against any further deflation.

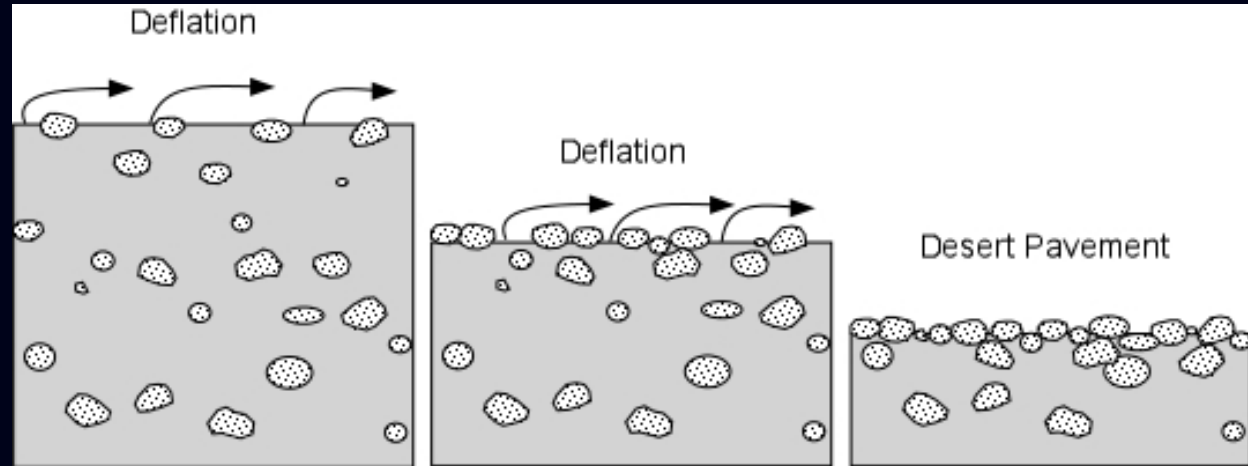

A white SUV is driving away on a two-lane desert road. The road is paved with light-colored gravel or sand, and the surrounding landscape is a flat, arid desert under a clear blue sky. The car is in the distance, centered in the upper right portion of the frame. The road has yellow double lines marking the lanes.

**What happens when you disturb the lag (desert pavement)?**



**This the open desert between Algeria and Timbuktu. Traffic has created a zone of channels scoured by the wind.**



# Compaction

- Lunar Regolith “Soil”
  - Fine particles, very loose, very fluffy, created by micrometeorite bombardment.
  - About 20 cm deep
  - Density about 0.9-1.1 g/cm<sup>3</sup>. Increases with depth to about 1.9 g/cm<sup>3</sup>. Porosity about 45%.
  - The regolith becomes progressively more compacted with depth.
- NEAs.....
  - Lower gravity may make it harder to compact.
  - Interparticle forces dominate.
  - Particle size profile with depth may be highly variable.

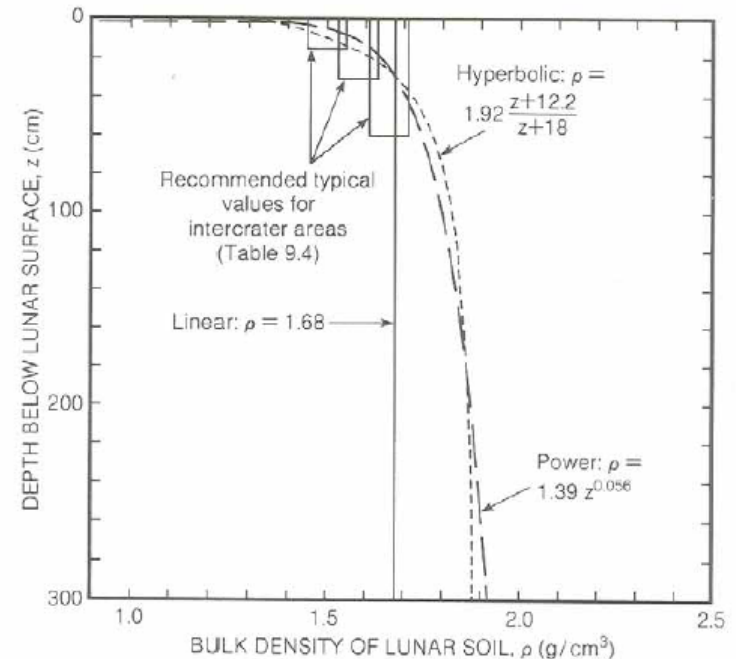

# Thermal Inertia

- Thermal Inertias of NEOs range from  $\sim 100$  to  $\sim 1000$   $\text{J m}^{-2}\text{K}^{-1}\text{s}^{-1/2}$ 
  - Moon:  $\sim 50$
  - Large Main Belt asteroids: 10 to 40
  - Bare rock: 2500
- Implications for regolith surfaces
  - NEO regoliths likely all coarser than the Moon's
  - Lower end likely “pebble” size ( $\sim\text{mm}$ )
  - Upper end has abundant boulders ( $> 0.5$  m)



# Thermal Inertia

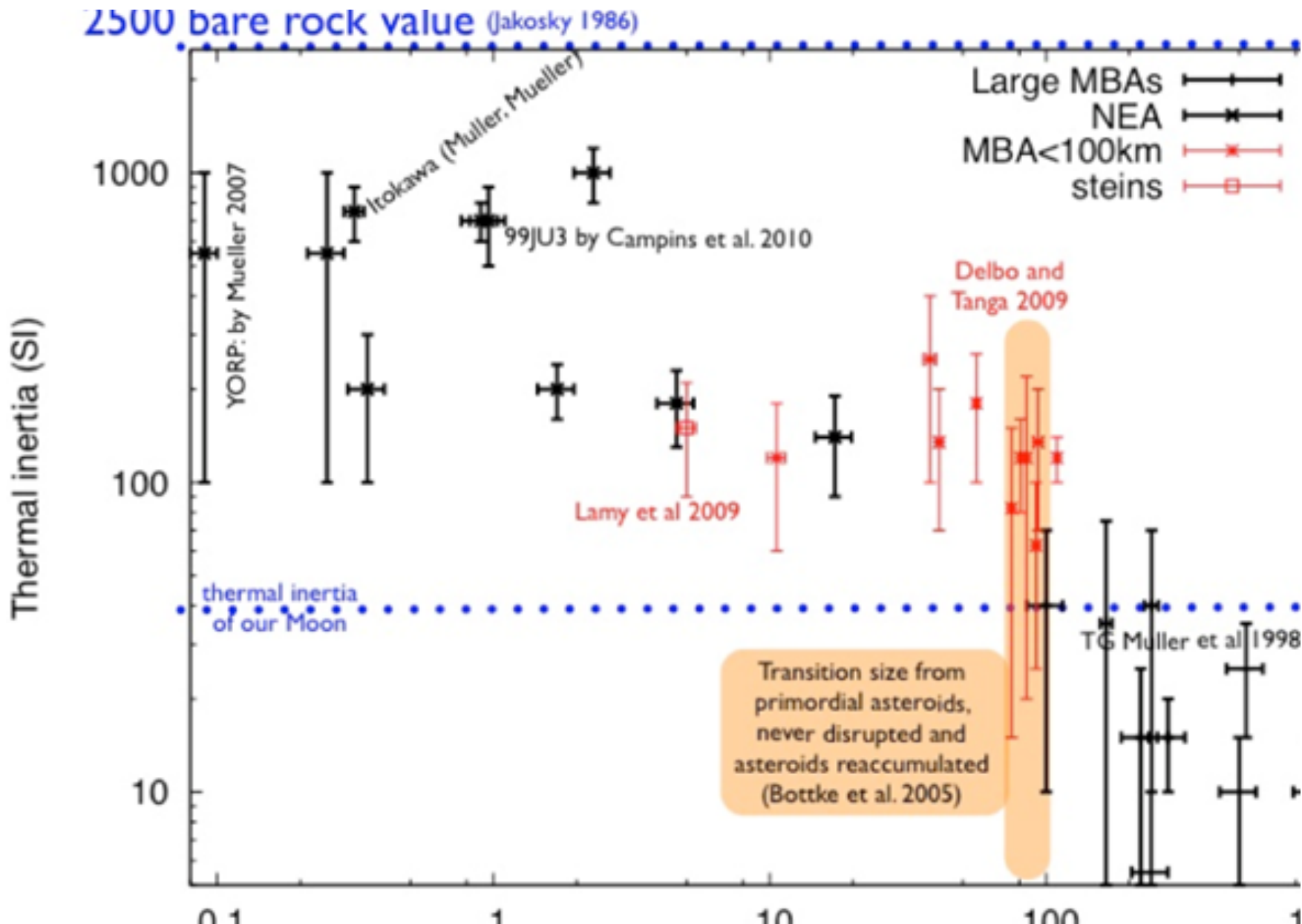

# Maybe Tommy Gold was right (about big Asteroids)?



Vesta

**TI ~ 15-40**



Eros

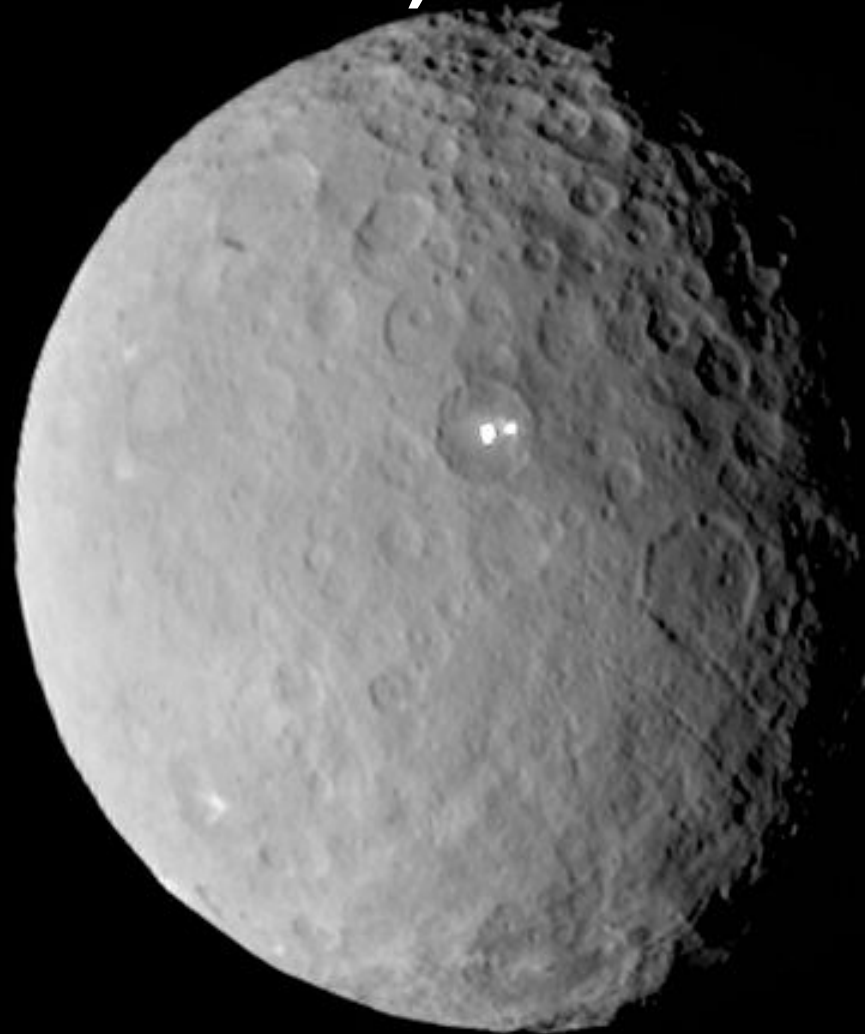

**TI ~ 18-40** Ceres

# Where do the fines come from?

- Turns out that thermal fragmentation from diurnal temperature variations breaks up rocks more quickly than micrometeoroid impacts, without the problem of ejection from the low-gravity body, creating fine-grained fragments.
- This effect works more strongly on the darker, carbonaceous asteroids (and more strongly with solar distance).

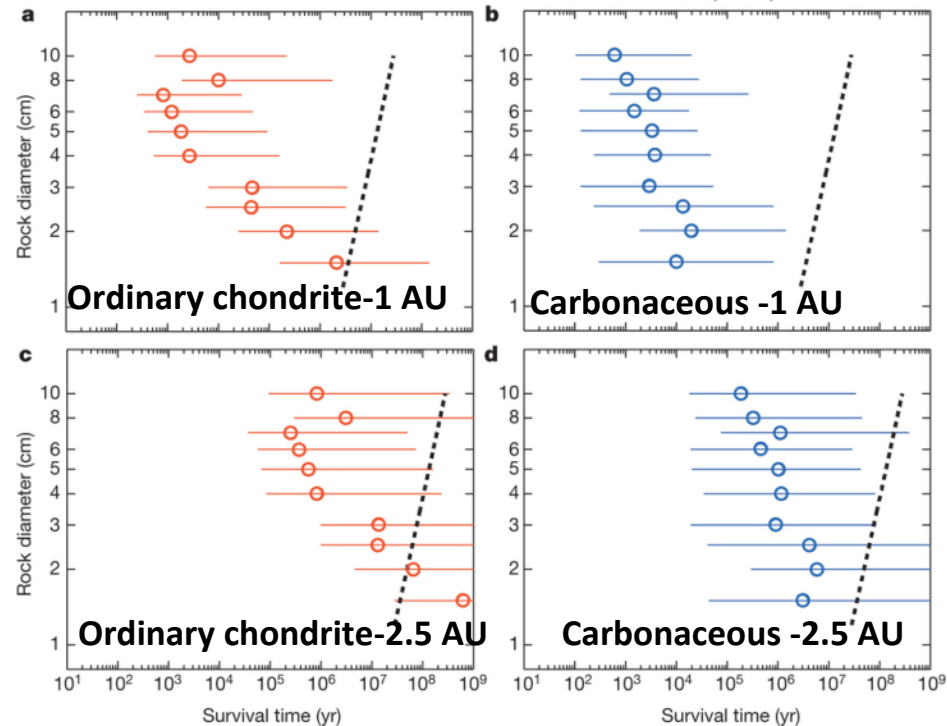
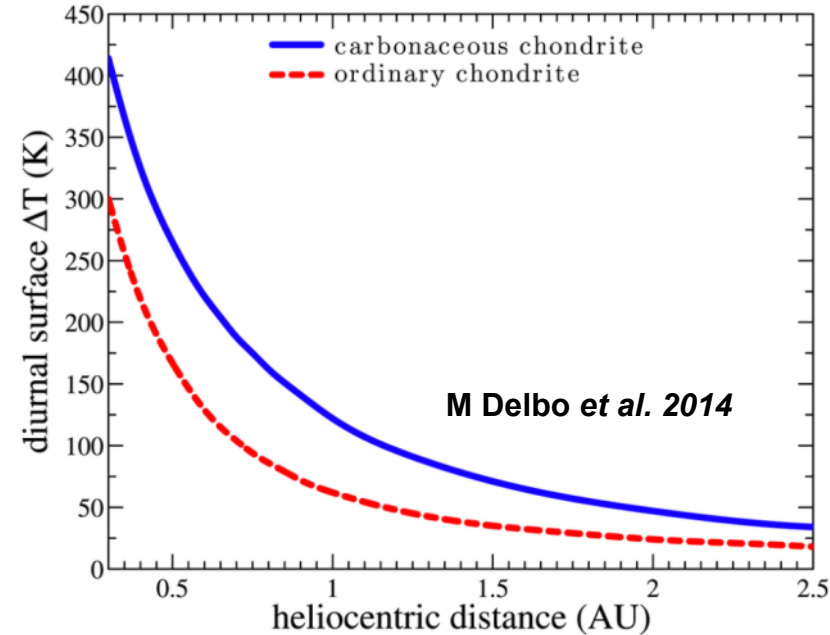

# 25143 Itokawa

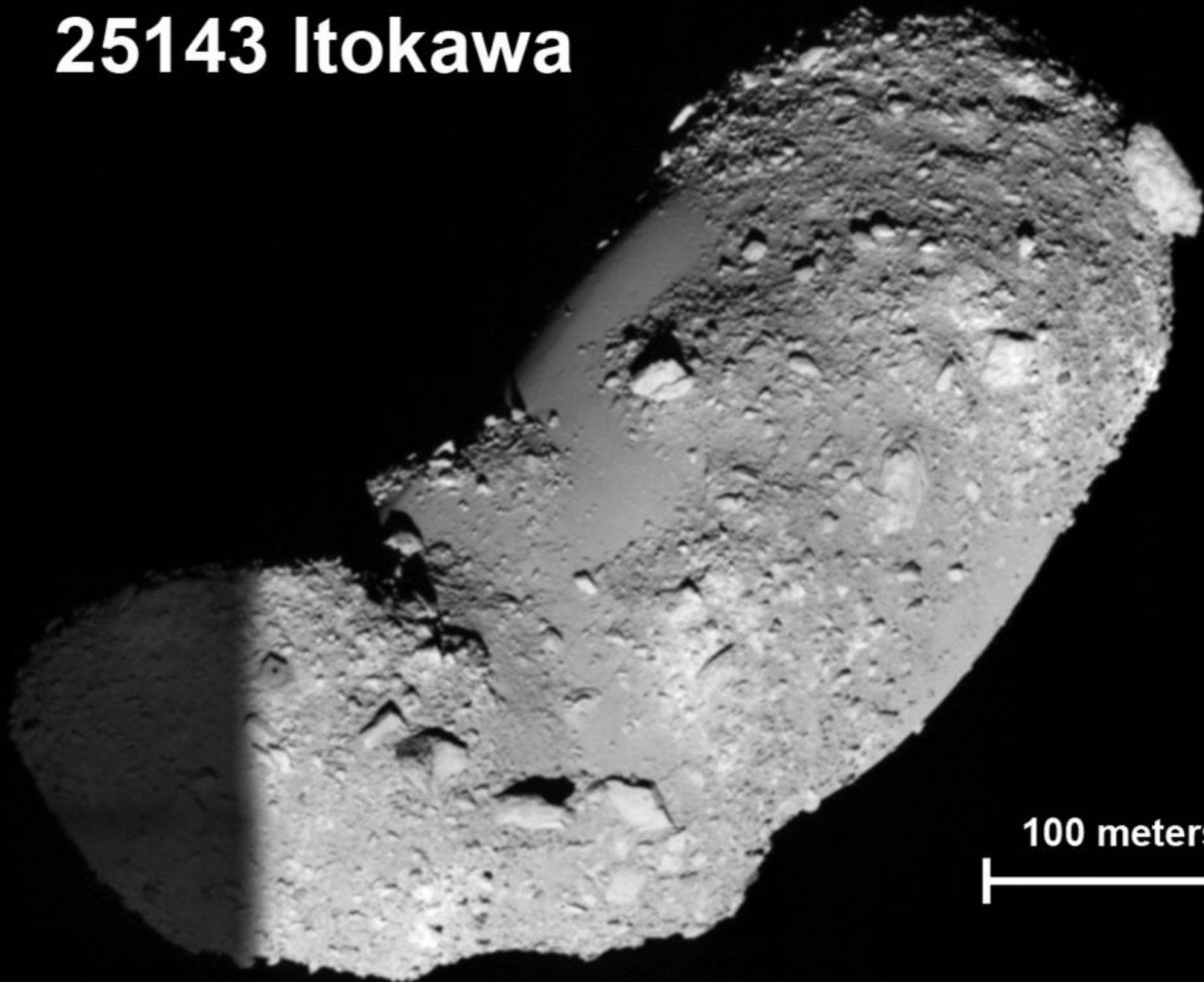

100 meters

Univ Tokyo/JAXA  
10 m

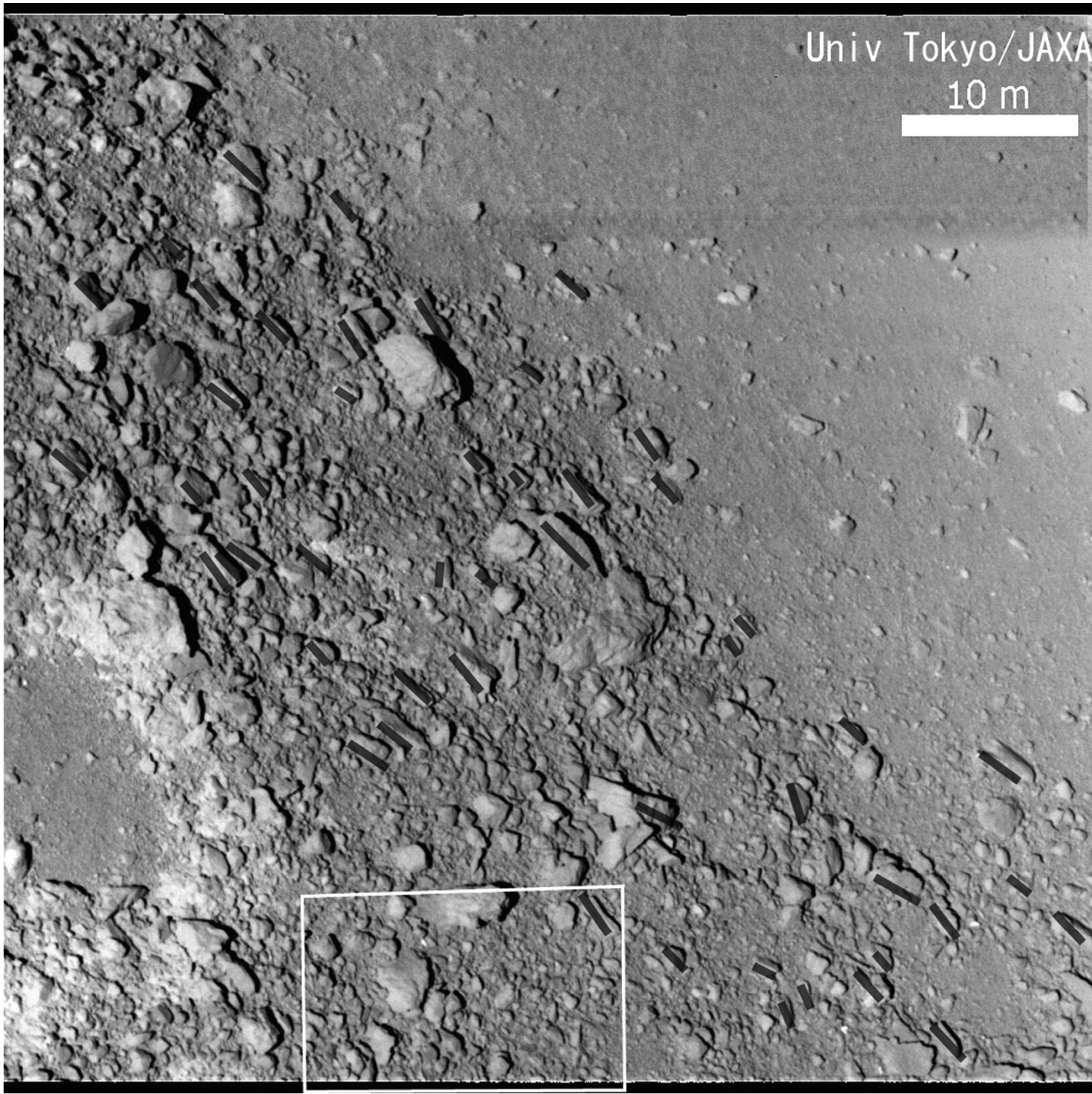



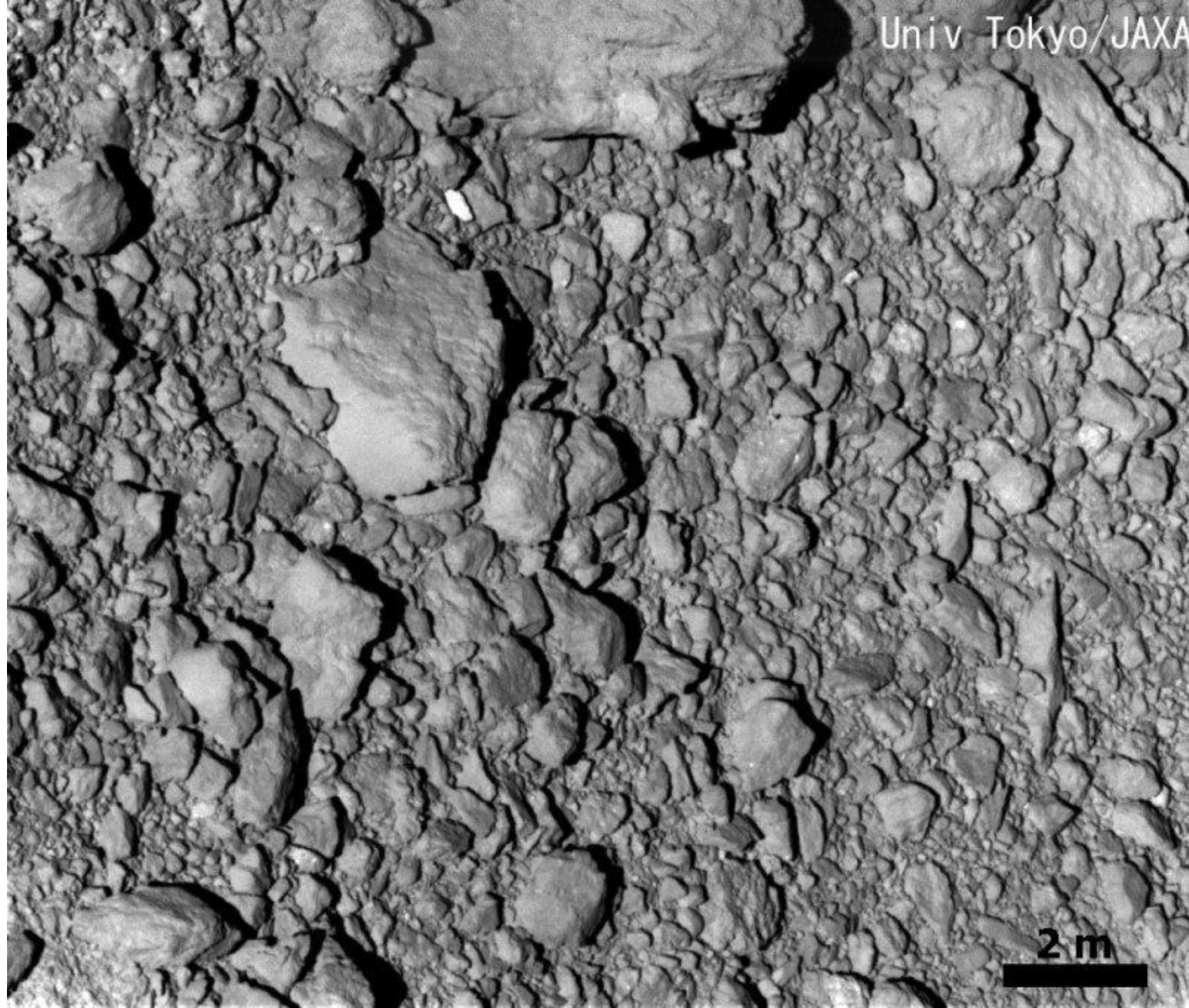

**1m**

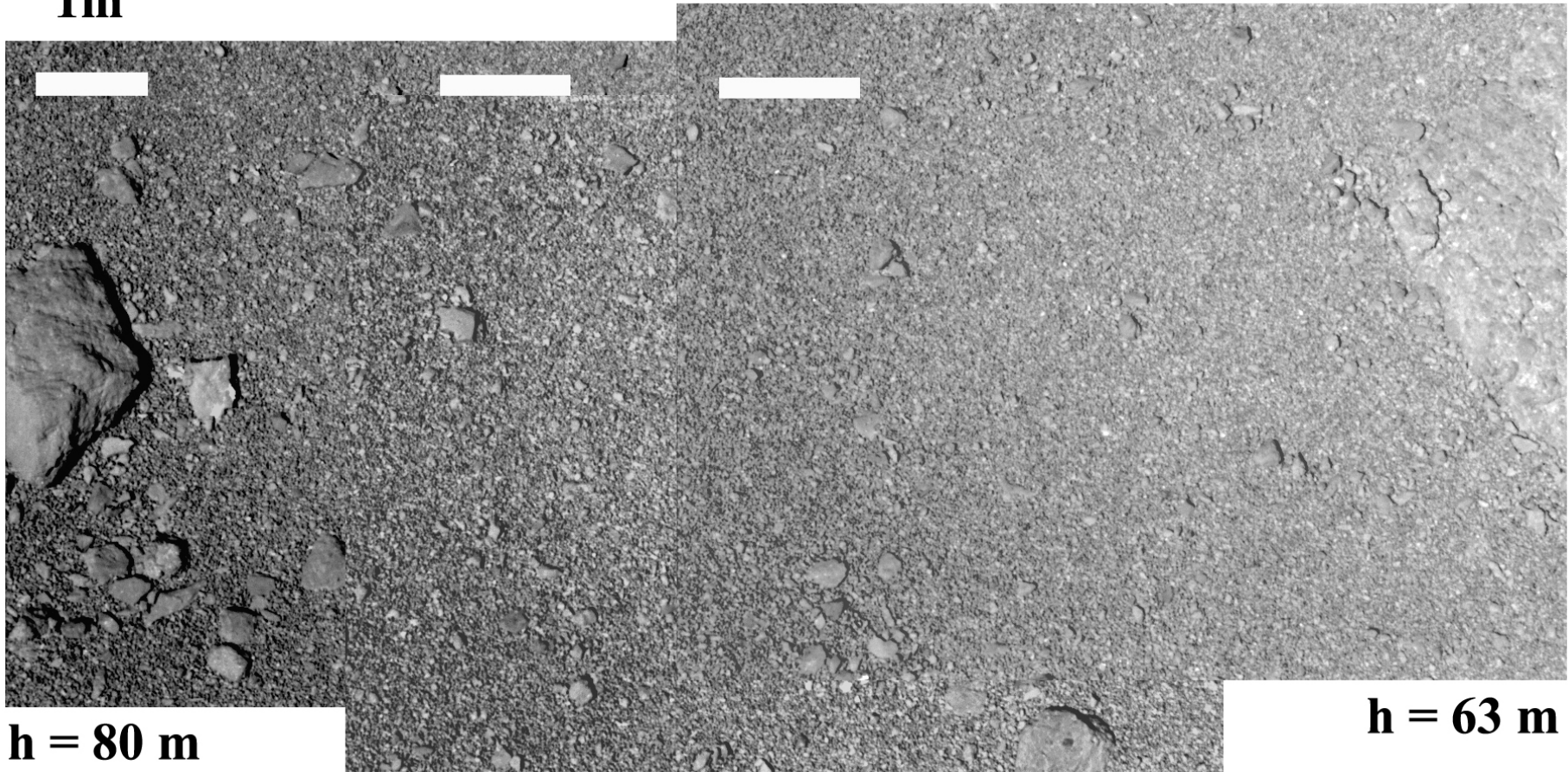

**h = 80 m**

**h = 68 m**

**h = 63 m**

# What is the Regolith Like Below the Surface?

- The rotation-rate data provides some insights.
- Rubble piles are literally held together by the cohesive forces between their smallest grains
- Small regolith “dominates” in surface area
  - Larger boulders and cobbles are coated in a matrix of finer grains that provides the body’s cohesive strength
  - Cohesive strength lower than the lunar regolith soil can allow ~10 m rubble piles to spin rapidly and survive.
- Regolith particle sizes probably drop quickly with depth.

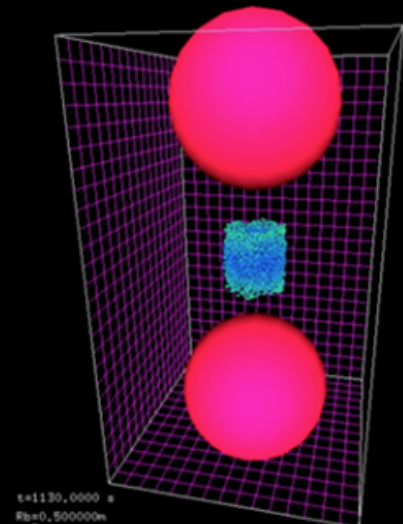

Cohesionless Regolith

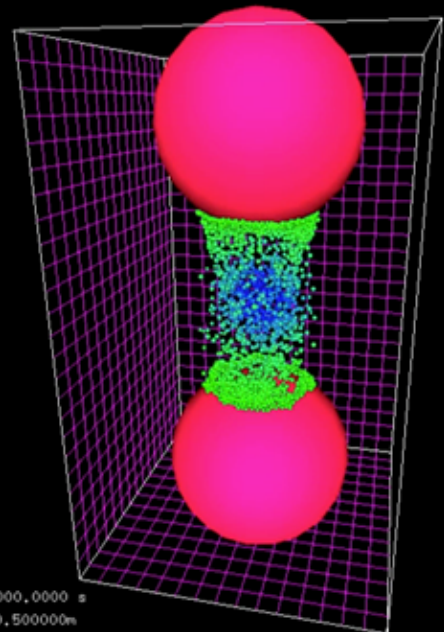

Cohesive Regolith

Rotation Period vs. Diameter, 2010, 3643 Asteroids

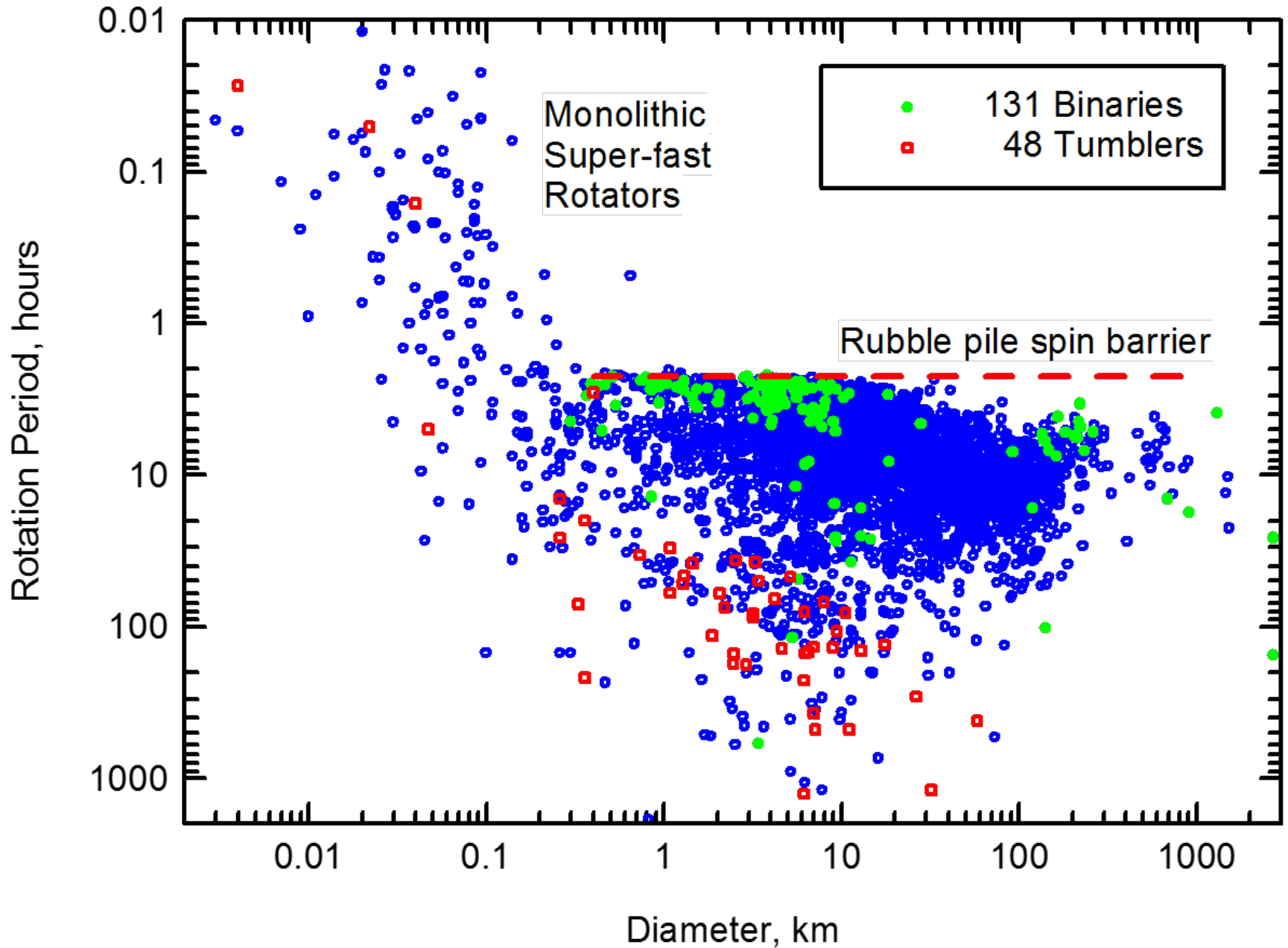

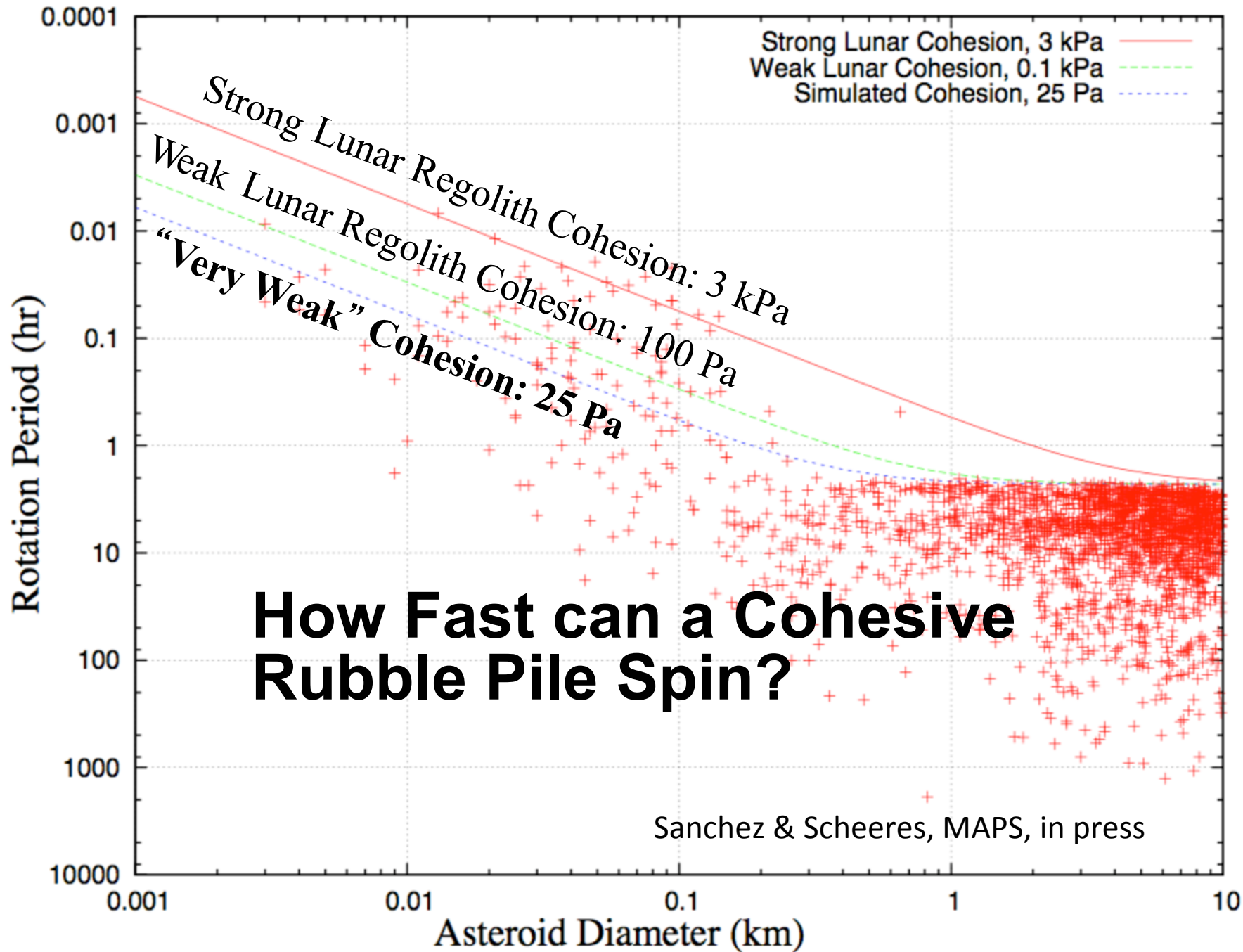

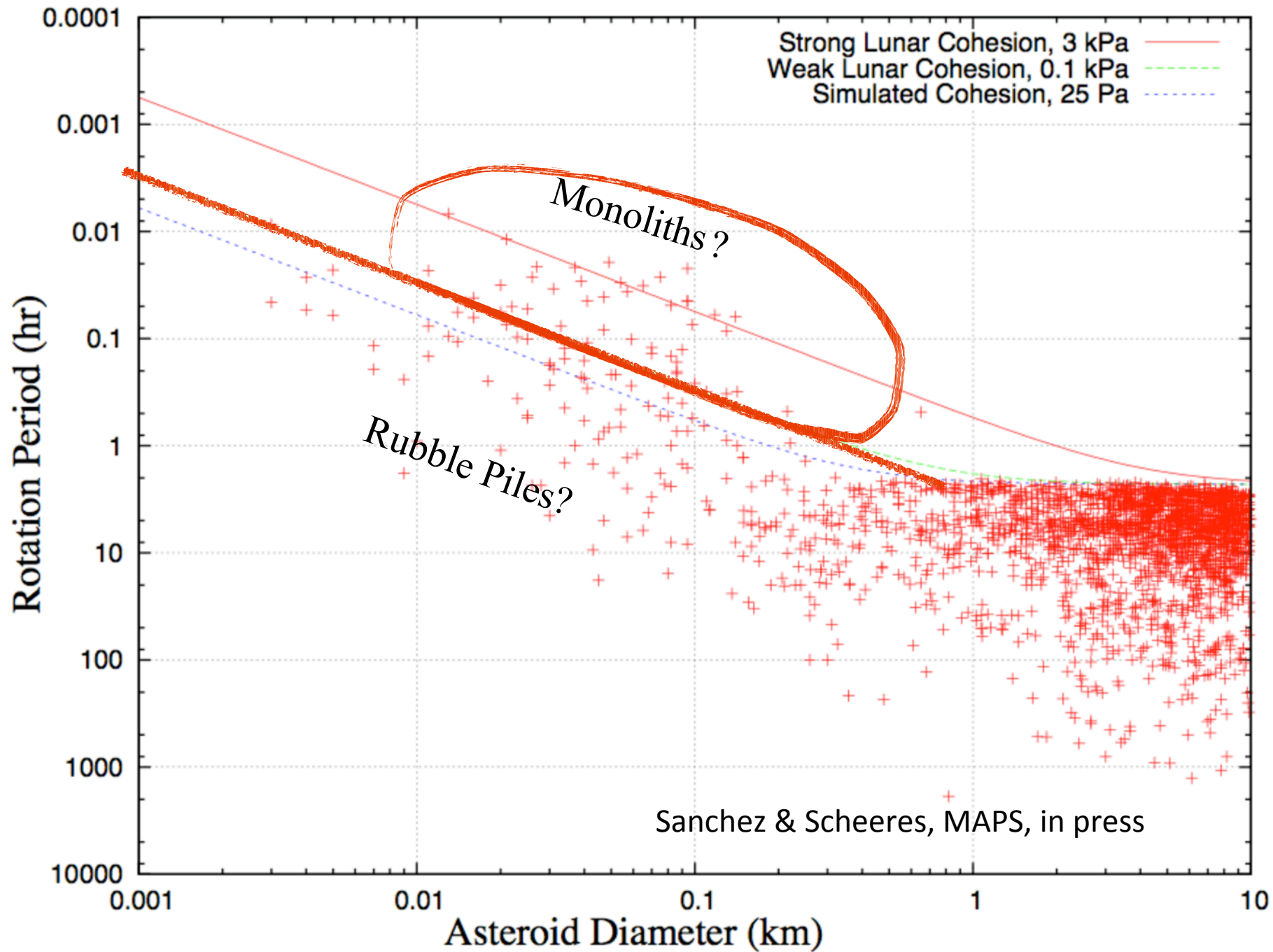

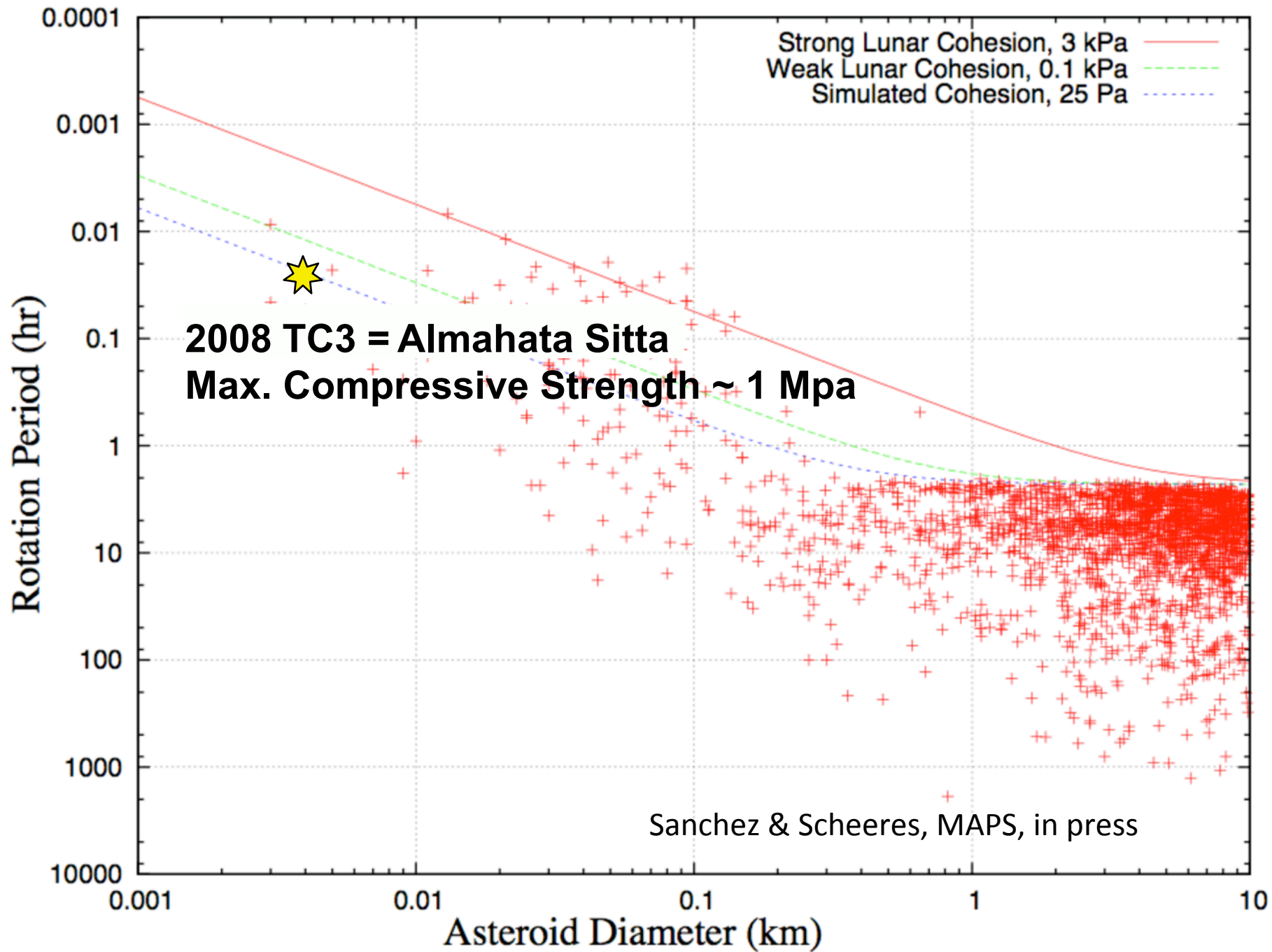

# The Physical Properties of Asteroid Regoliths

- That VERY MUCH depends on the asteroid.
- Start with Chondrites (ordinary, enstatite)
  - Mineralogy: olivine, pyroxene, metal, sulfides.
  - Cobbles and boulders are very, very tough (unreinforced concrete 20 Mpa, coherent OC ~50-450 Mpa).
  - Highly depleted in volatiles
- Regolith: Stony to dusty depending on asteroid size

Release 051101-3 ISAS/JAXA

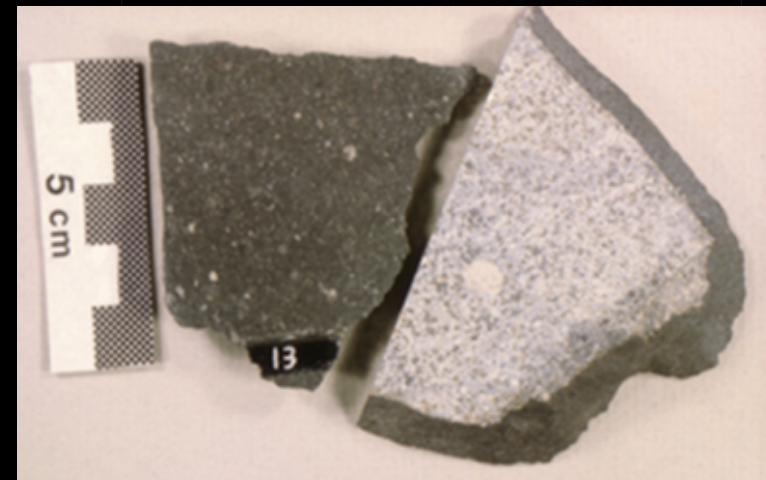



# Anhydrous Carbonaceous Chondrites

- CV, CO, CR, CK, CH
- Mineralogy much like ordinary chondrites (with chondrules)
- Mineralogy: olivine, pyroxene, metal, sulfides.
- Very strong (range up to 200 Mpa). Tough to break up.
- Highly depleted in volatiles
- Regolith: Stony to dusty depending on asteroid size

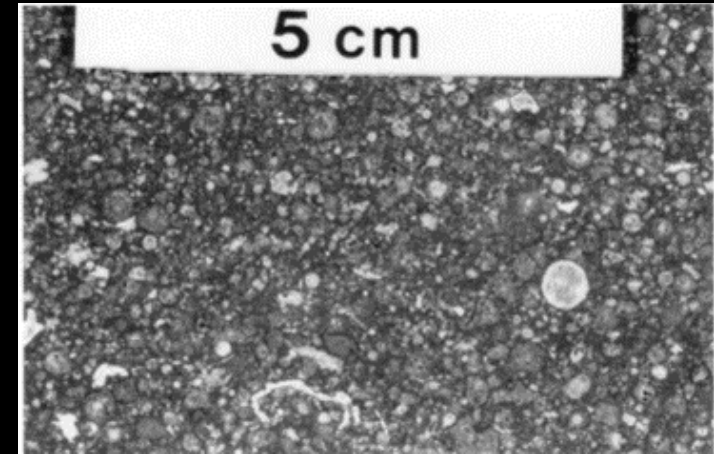

# Volatile Rich Carbonaceous Chondrites

- CI, CM, C2, Tagish Lake types... some essentially soggy dirt clods
- Mineralogy includes:
  - Hydrated clays
  - Iron Oxides, Iron Sulfides
  - Olivine
  - Organics
  - Ice
- Most weaker than OC's, some very weak ~1-50 MPa.
- Regoliths
  - Depends on asteroid size
  - Lags may insulate enough to preserve ice as some depth?

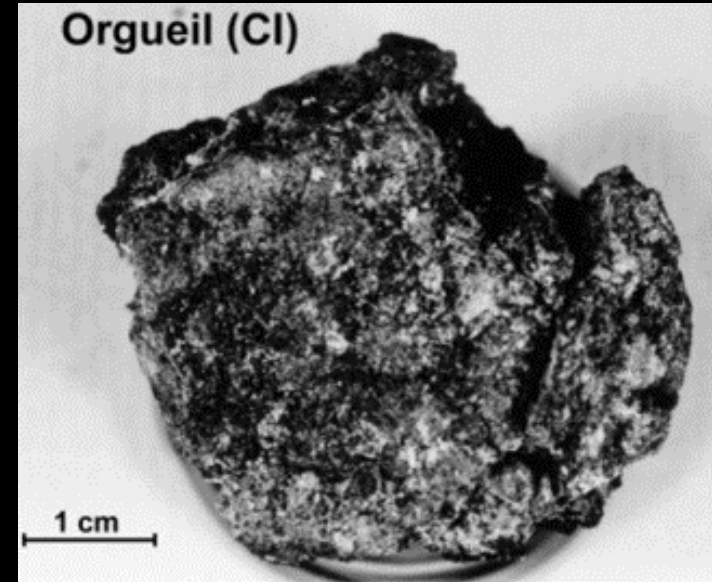

# Irons and Stony Irons



- Free Iron and nickel
- Mafic Silicates (olivine, pyroxene): Mostly olivine.
- Iron Sulfates (troilite): Relatively weakly bound sources of sulfur and iron.
- Regoliths:



- Iron is a lot tougher and more ductile than silicates (except when cold)
- Think about an iron fragment gravel?
- Silicate component would be finer than the metal component

# Surface Properties Wrap-up

- **Small asteroid (<40-100 km diameter) regolith will probably be:**
  - Much coarser than lunar regolith
  - Boulder, cobble rich (desert pavement)
  - Surface fines will be depleted by the solar wind (for <10km)
  - But fines will probably be abundant below the lag surface.
  - Rubble Pile structure
  - Compaction will be less efficient than the lunar case
  - Will be space weathered
- **Large Asteroids (>100 km diameter)**
  - Much dustier than the Moon
  - Impact speeds too low to make agglutinates
  - Enough gravity to retain fines
  - Rubble pile structure
  - Compaction may be less efficient than the lunar case
  - Will be space weathered

# Strata-1

- Pre-launch configurations:
- Passive experiment - uses the ISS gravity and vibration environment to simulate asteroid conditions
- 4 tubes loaded with 4 simulants:
  - spherical glass beads
  - glass shards
  - meteorite simulant
  - carbonaceous chondrite
- Video data will be used to analyze layering and particle motion

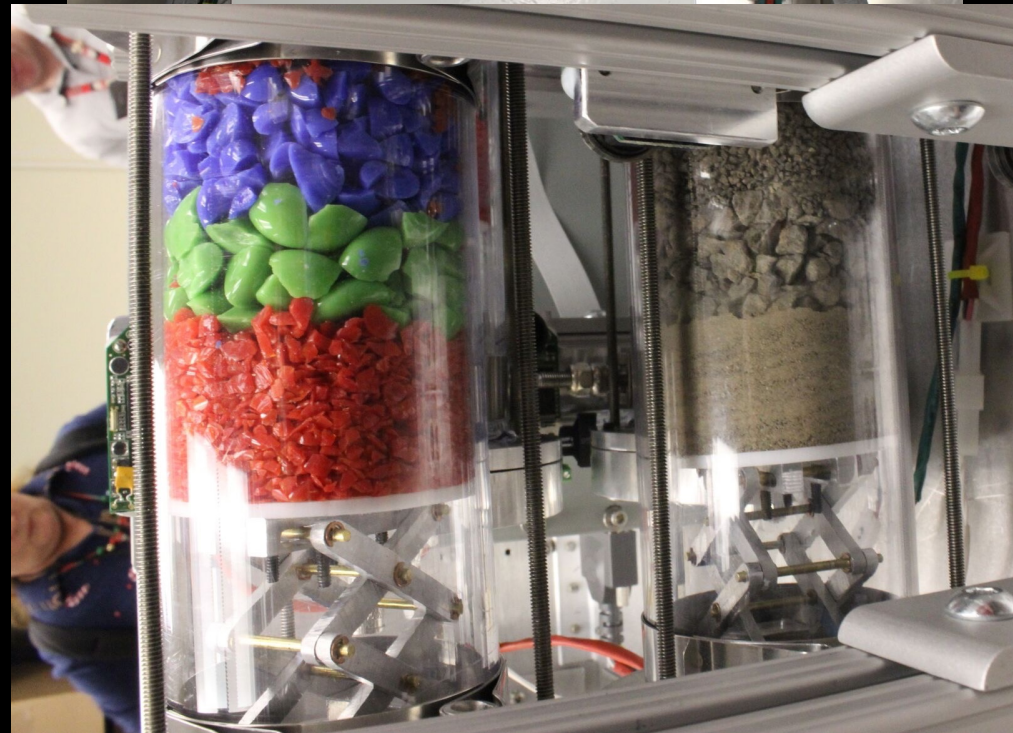
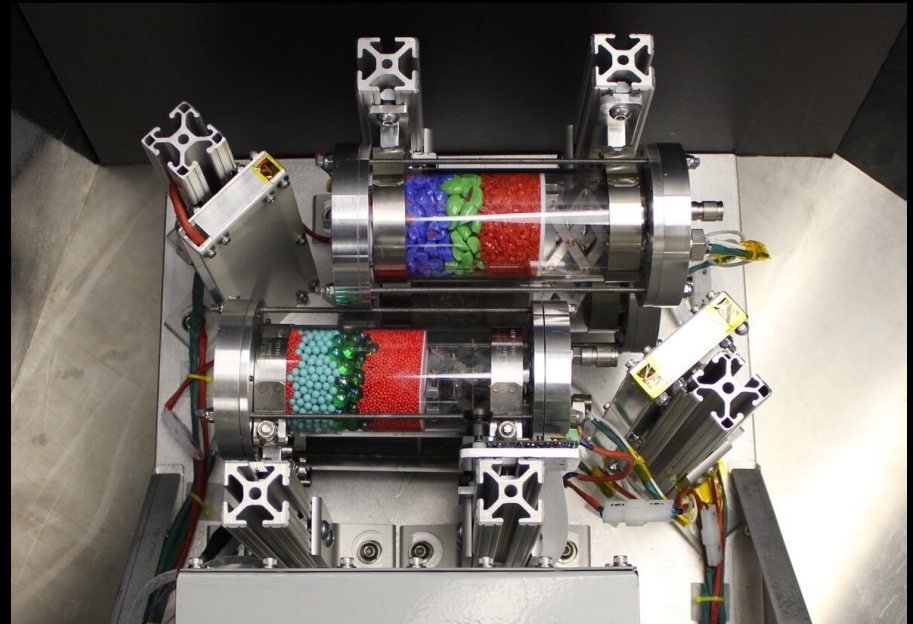

# Strata-1

Snapshots in time ...

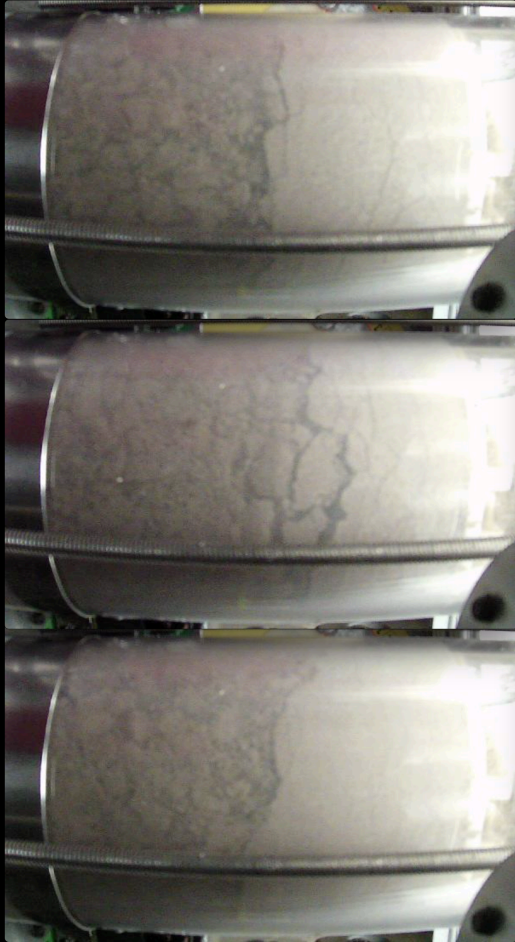

Meteorite simulant



Glass shards









# Low-velocity impact experiment

- Exploration activities on asteroid surfaces
- Secondary collisions on small asteroids
- Impacts between ring particles
- Impacts in the protoplanetary disk



# The PRIME Experiment

**PRIME:**  
**P**hysics of  
**R**egolith  
**I**mpacts in  
**M**icrogravity  
**E**nvironments

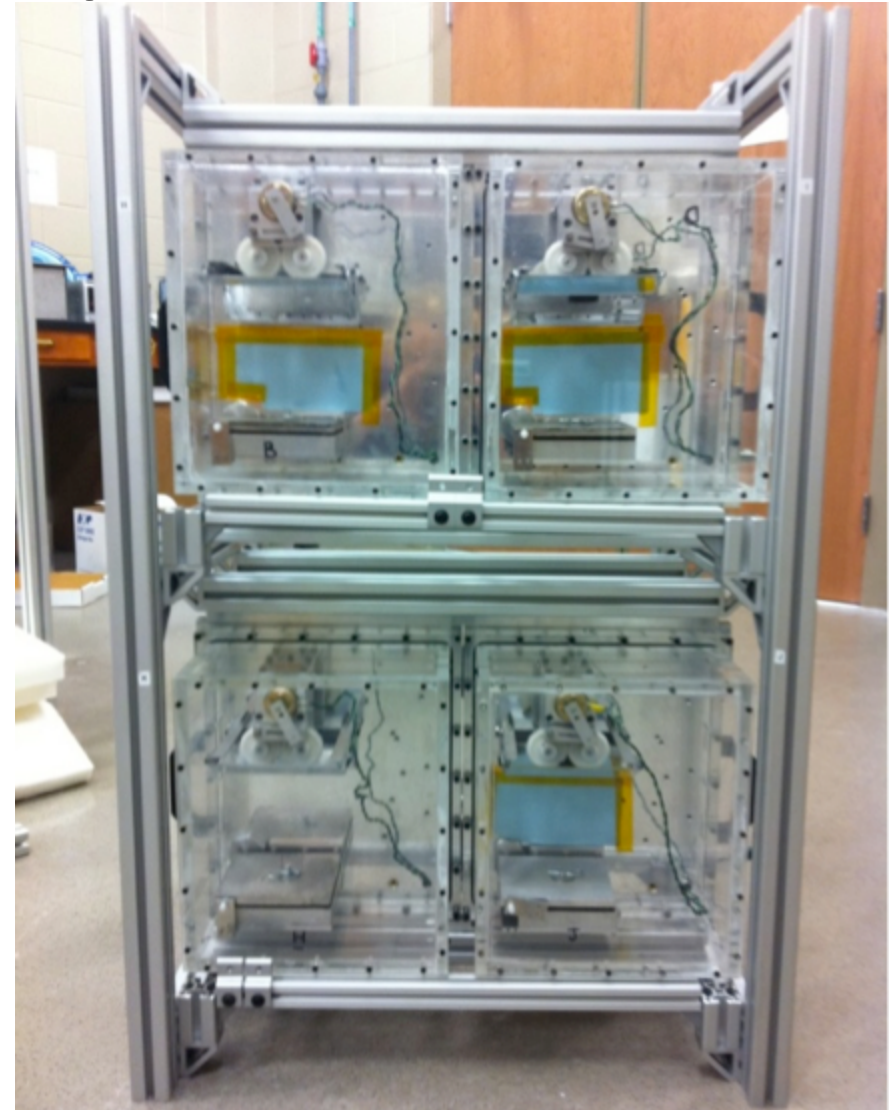

# Previous Campaigns

- July 2002
- August 2002
- January 2003
- April 2003
- May 2003



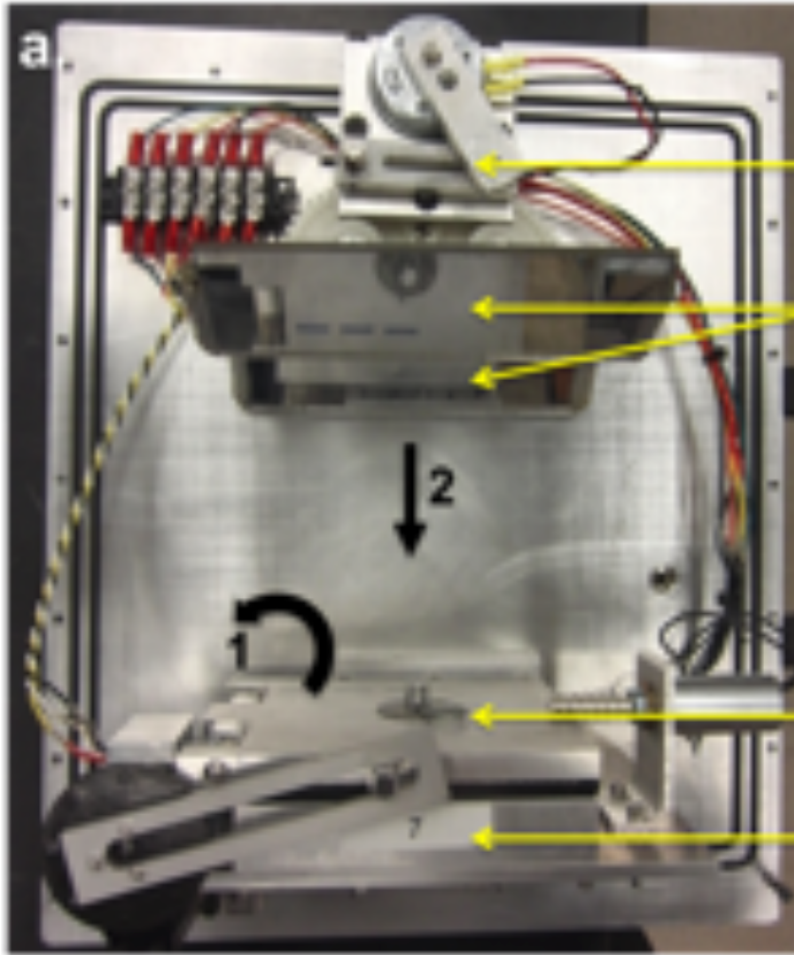

Launch Mechanism

Mirrors

Tray Door

Regolith Tray

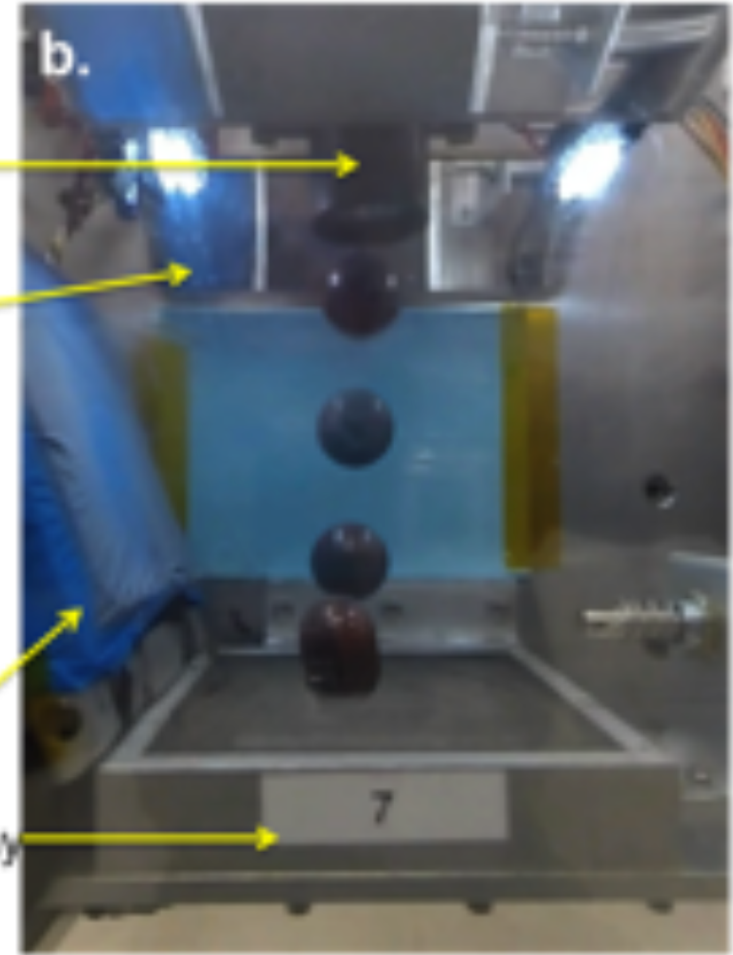

# The PRIME Flight Setup

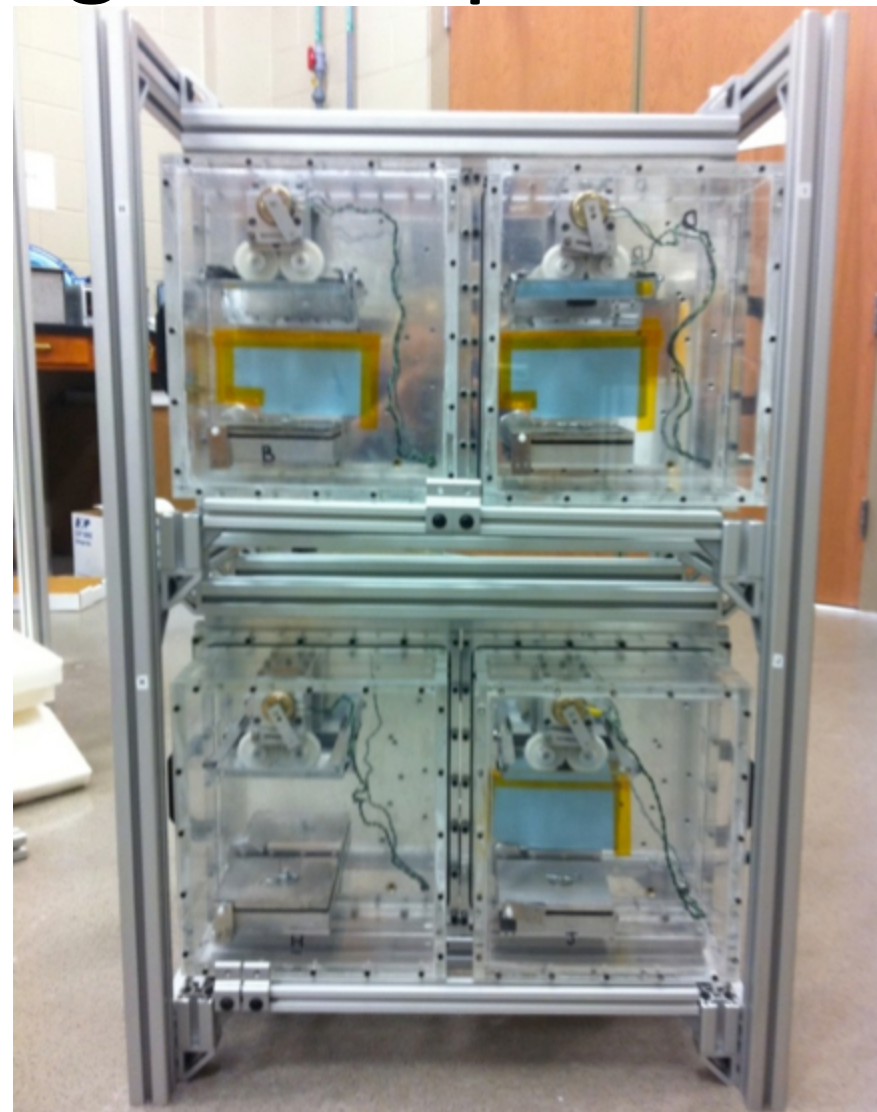
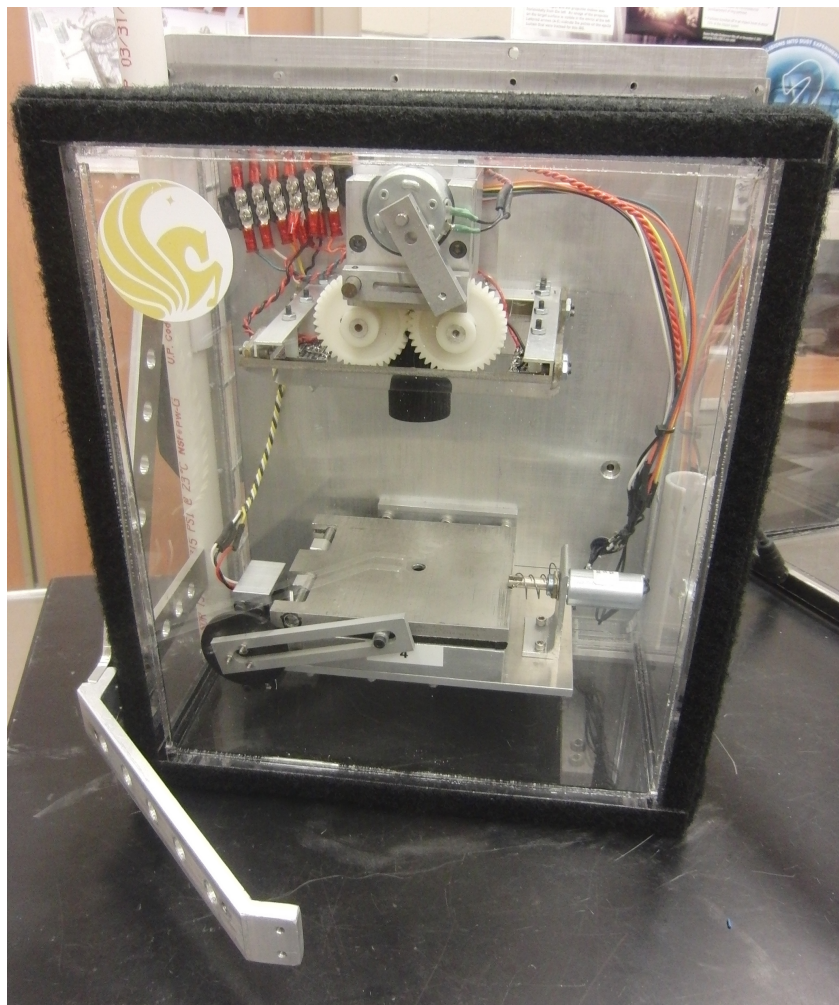

# PRIME-3 Experiment Plan

box #	regolith	impact speed	spring	k [N/m]	marble material	marble weight [g]
1	sand	15 cm/s	W	5.25	glass	9.82
2	sand	15 cm/s	W	5.25	steel	28.2
3	sand	25 cm/s	W	5.25	glass	11.76
4	sand	25 cm/s	W	5.25	brass	30.75
5	sand	50 cm/s	W	5.25	glass	9.9
6	sand	50 cm/s	2	72.3	steel	28.2
7	JSC-1	25 cm/s	W	5.25	glass	9.82
8	JSC-1	25 cm/s	W	5.25	steel	28.2

- Size distribution of the regolith particles: between 150 and 250  $\mu\text{m}$

**TABLE 2: PRIME-3 2014 Flight Campaign Results Summary**

Flight	Box	Regolith	Marble Mass [g]	Ejecta	Rebound	Impact speed [cm/s]
1	1	sand	9.82	Y		48.45
	3	sand	11.76	Y		49.72
	4	sand	30.75	A		43.19
	5	sand	9.9	Y		43.75
	6	sand	28.2			19.87
	7	JSC	9.82		Y	33.32
	8	JSC	28.2			19.56
	2	2	sand	28.2		Y
3		sand	11.76	A		31.52
4		sand	30.75	A		38.4
5		sand	9.9	Y	Y	38.73
6		sand	28.2			13.6
7		JSC	9.82		Y	5.55
8		JSC	28.2		Y	14.45
3		1	sand	9.82	Y	
	3	sand	11.76	Y		26.38
	4	sand	30.75	A		31.84
	5	sand	9.9	A		48.18
	6	sand	28.2			15.2
	8	JSC	28.2		Y	4.02
4	1	JSC	9.82	Y	Y	25.85
	3	sand	11.76	Y	Y	20.94
	4	JSC	30.75	A		27.77
	5	sand	9.9	A		52.93
	6	sand	28.2			10.02
	8	JSC	28.2		Y	13.38

~5-50 cm/s

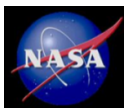

# PRIME-3

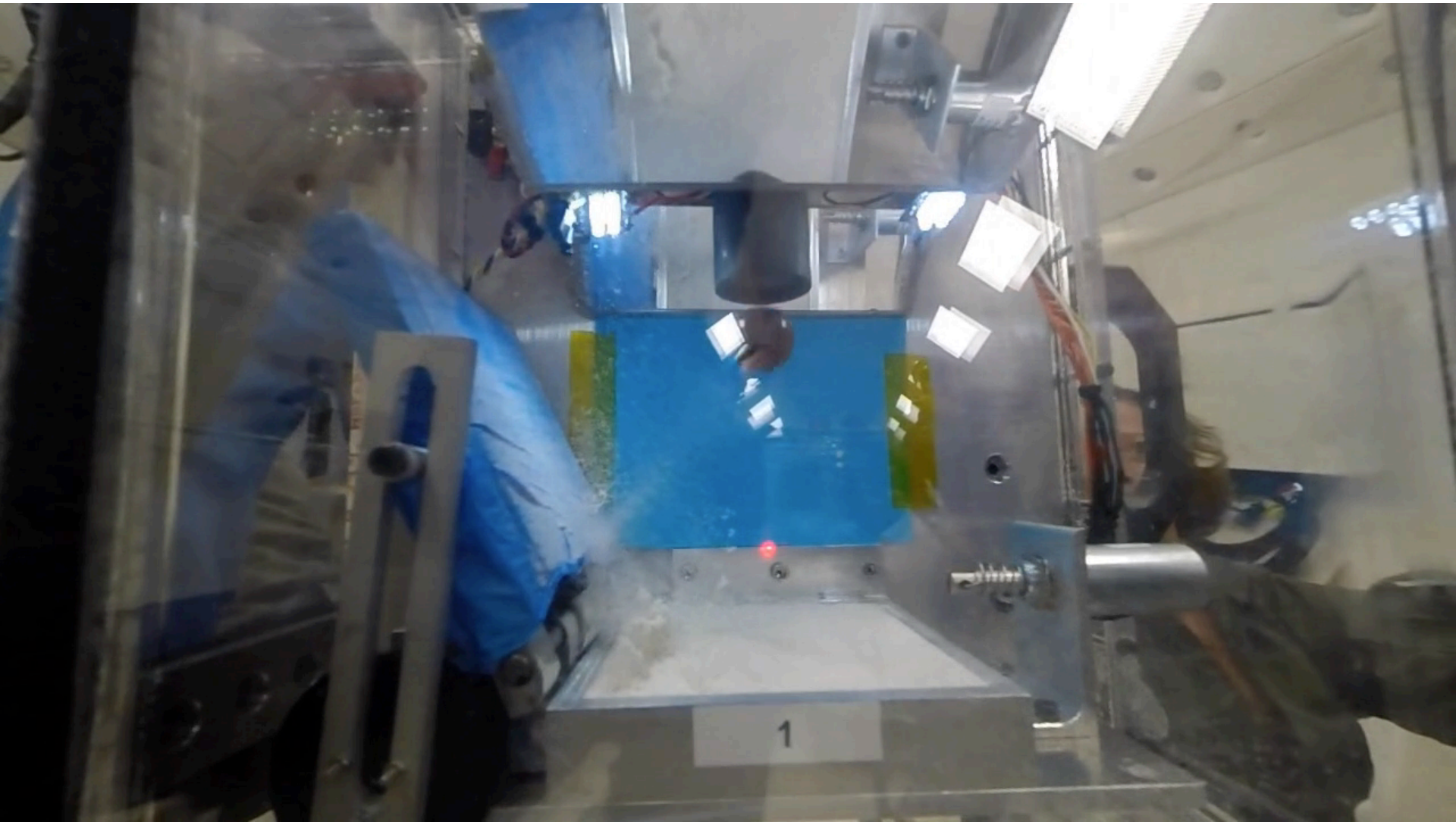



# Experiment Data — Microgravity

- 9 impacts with rebound: quartz sand

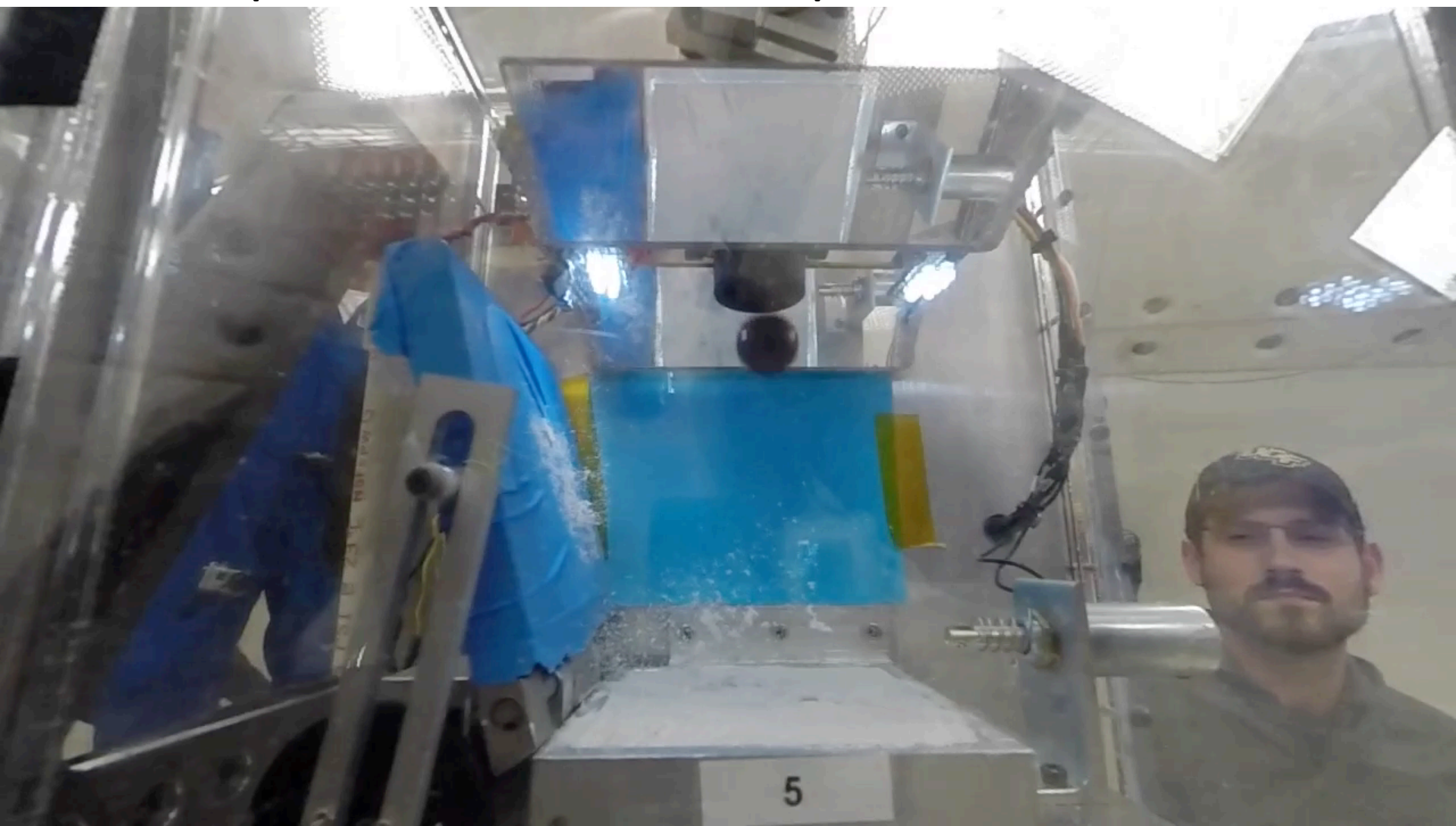

# Experiment Data — Microgravity

- 9 impacts with rebound: JSC

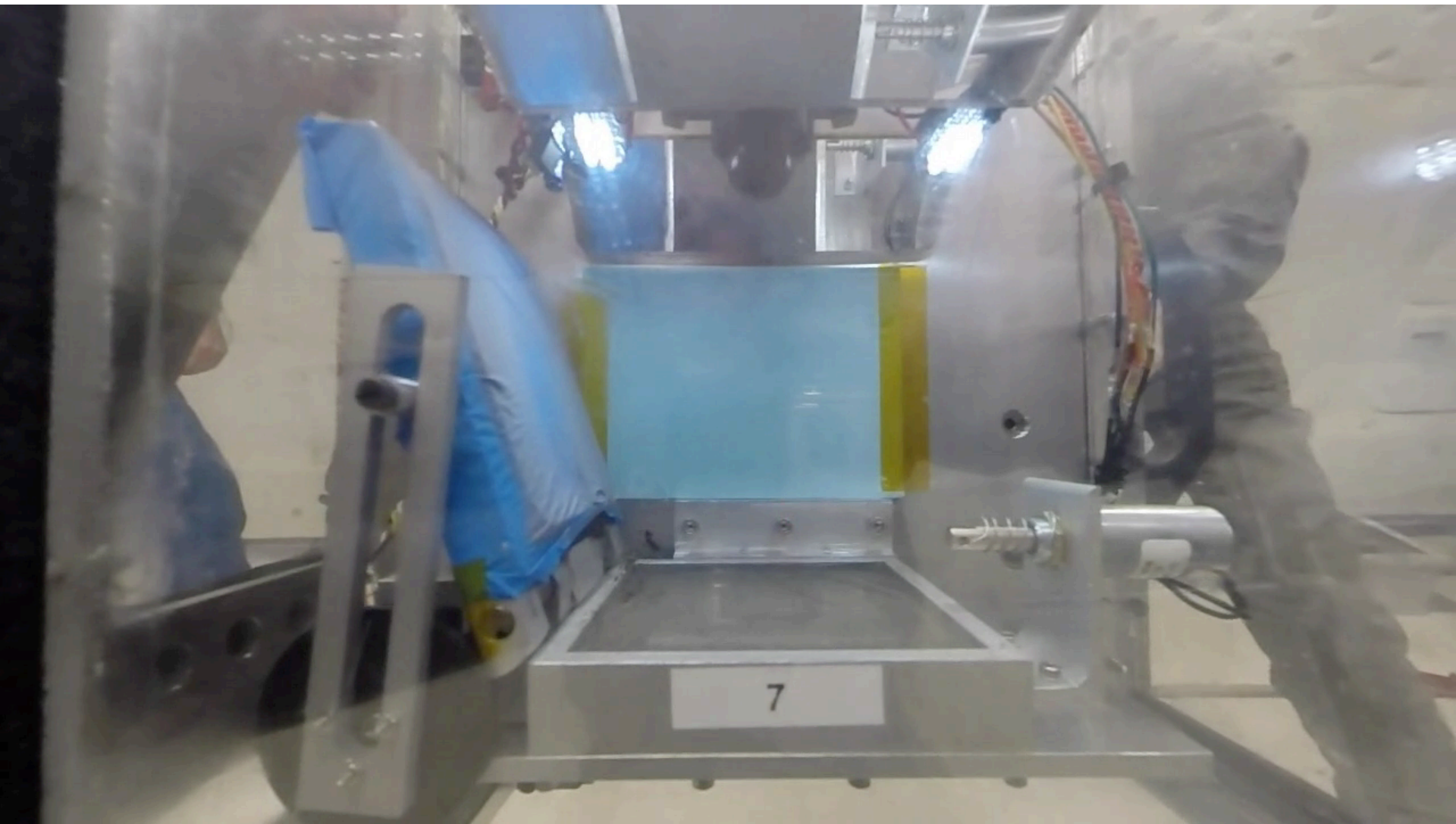

# Experiment Data — Microgravity

- 8 impacts with ejecta

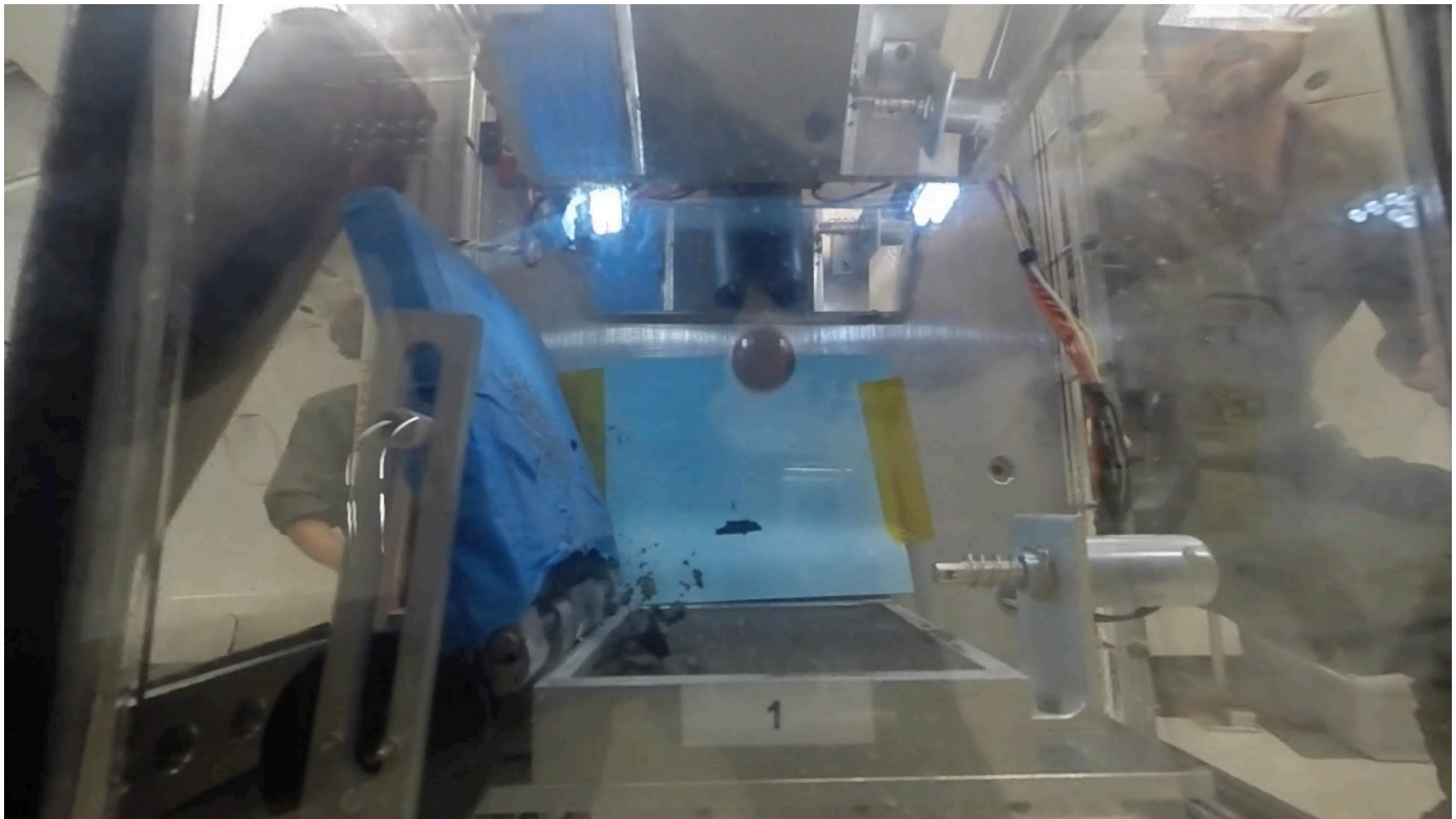

# Experiment Data — Asteroid g-level

- 7 impacts at 0.05g:JSC

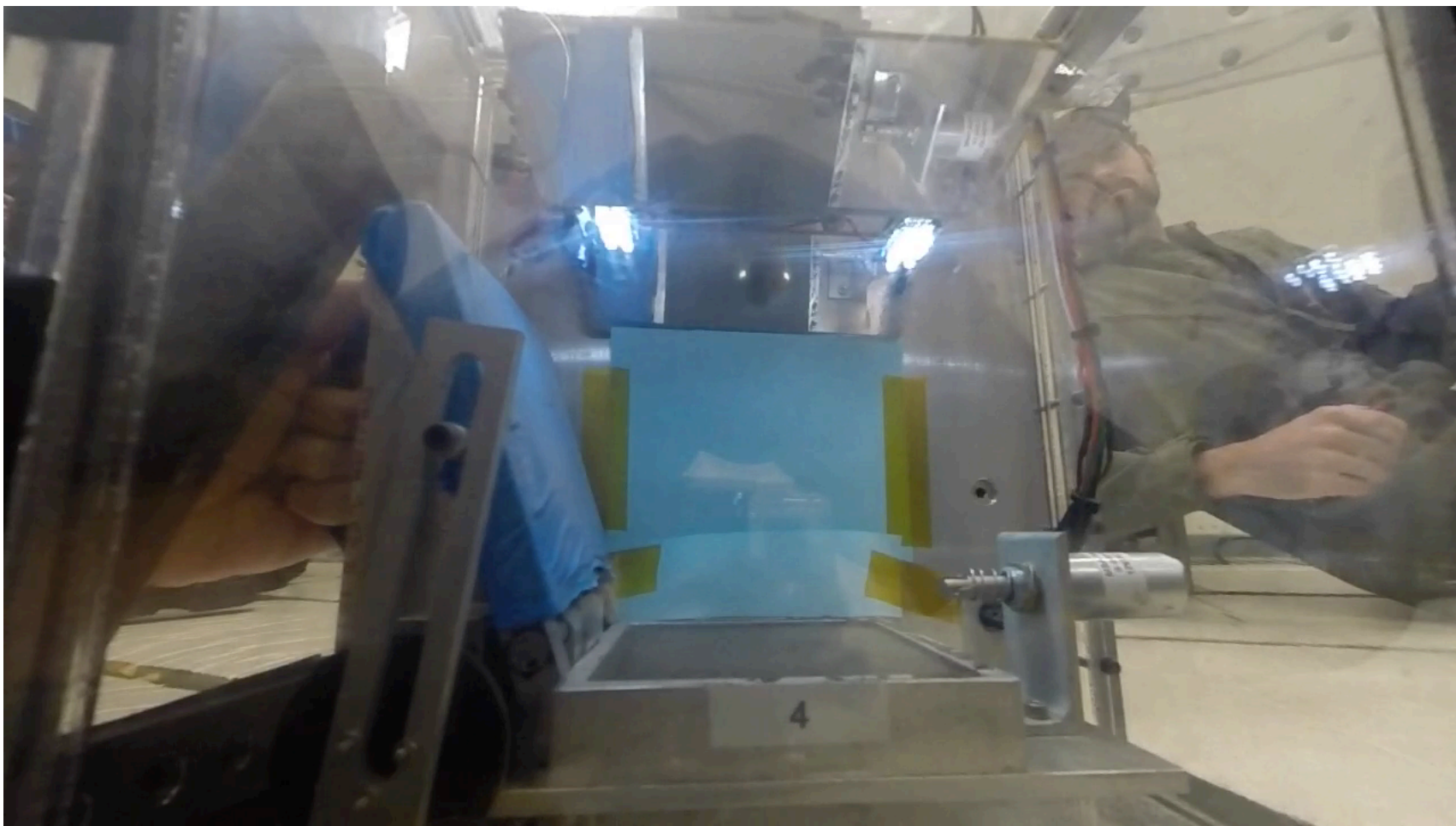

# Experiment Data — Asteroid g-level

- 7 impacts at 0.05g: quartz sand

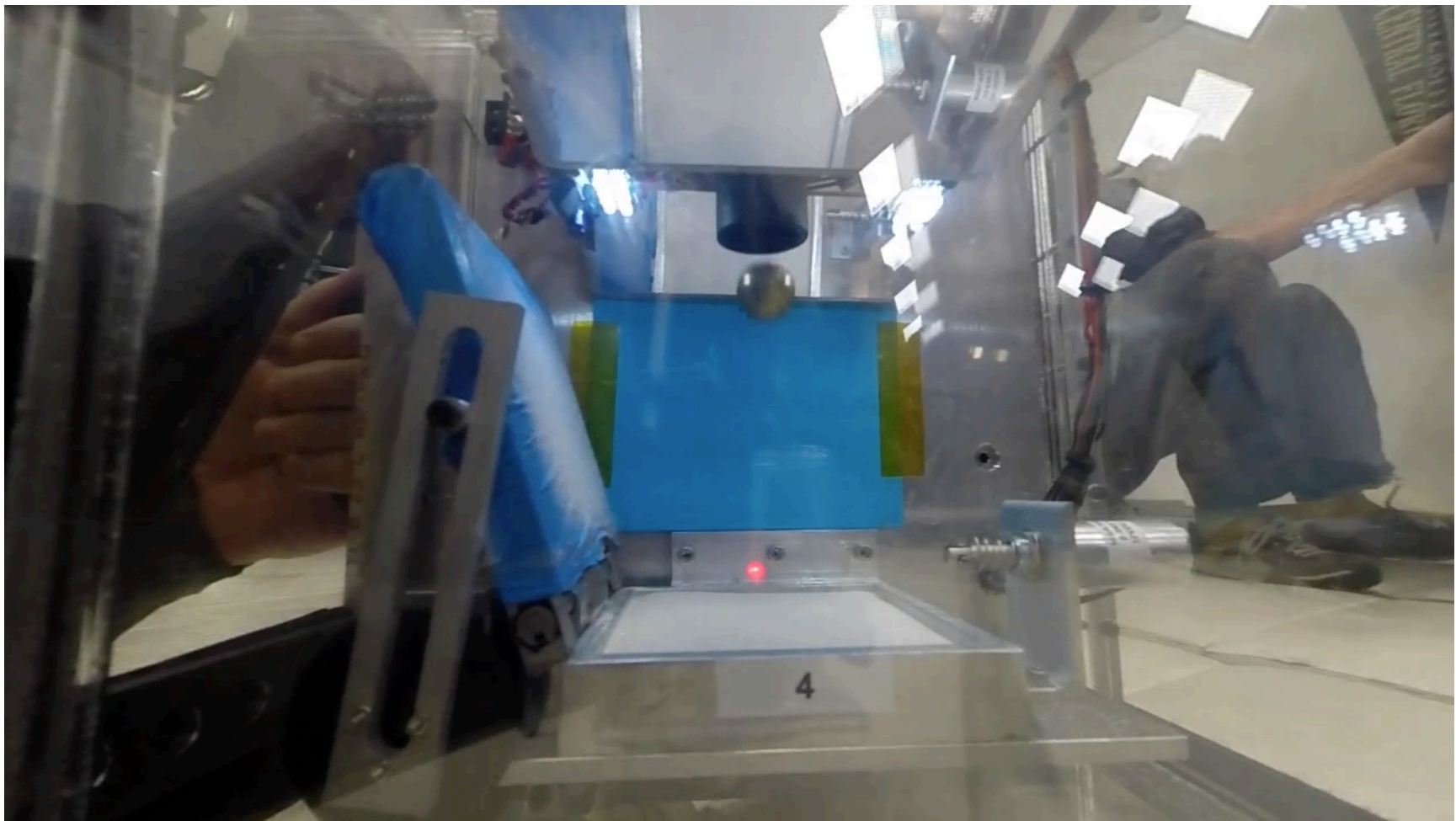

# Data Analysis

- Rebound collisions



- Coefficient of restitution of a cm-sized projectile on a bed of regolith

- Ejecta collisions



- Velocity profile of the ejected particles

- All collisions



- Crater opening speed
- Crater size

# Coefficient of Restitution on a Regolith Bed

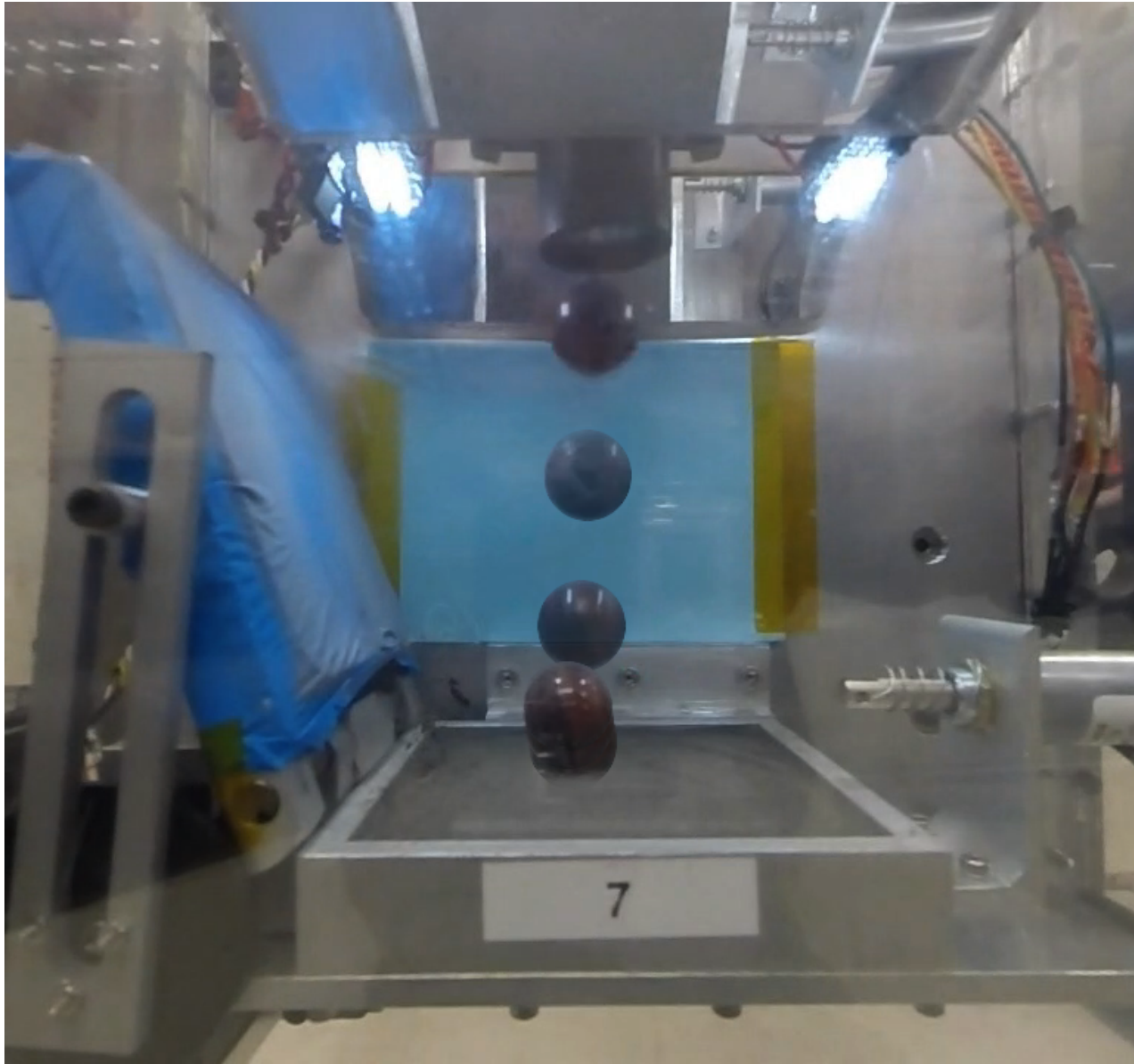

# Coefficient of Restitution on a Regolith Bed

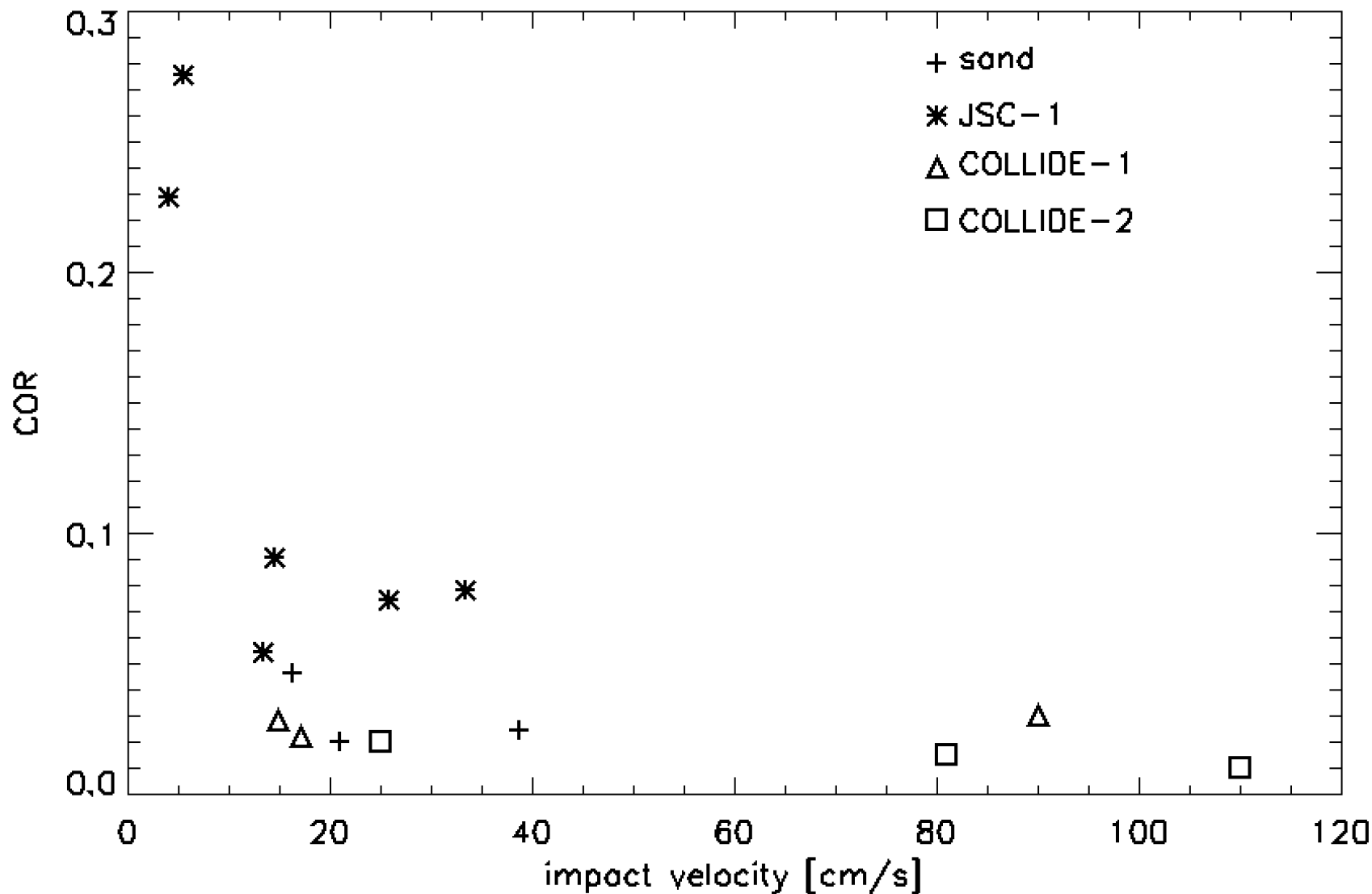



# Data Analysis — Ejecta Tracking

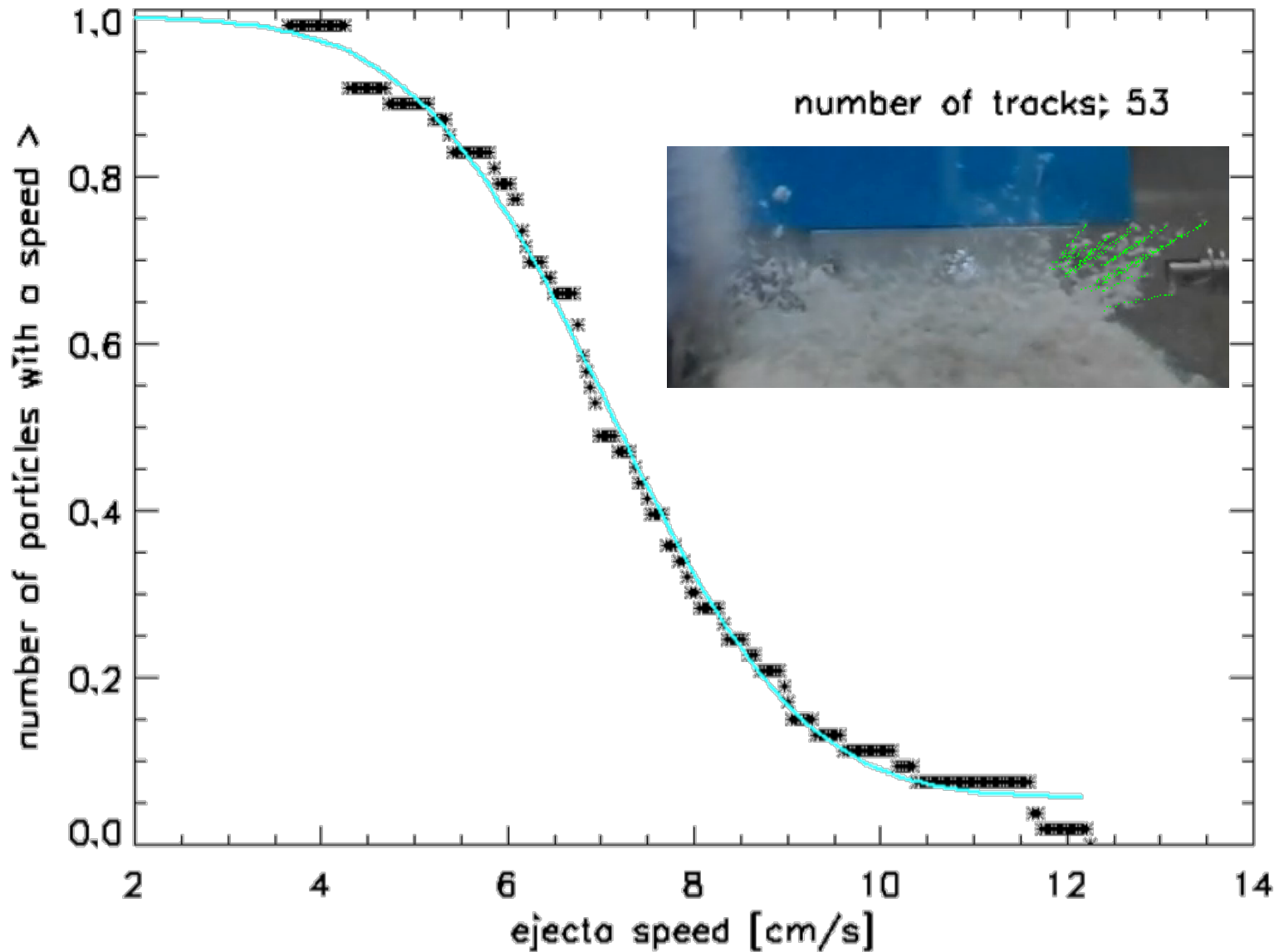

# Results— Ejecta Speeds

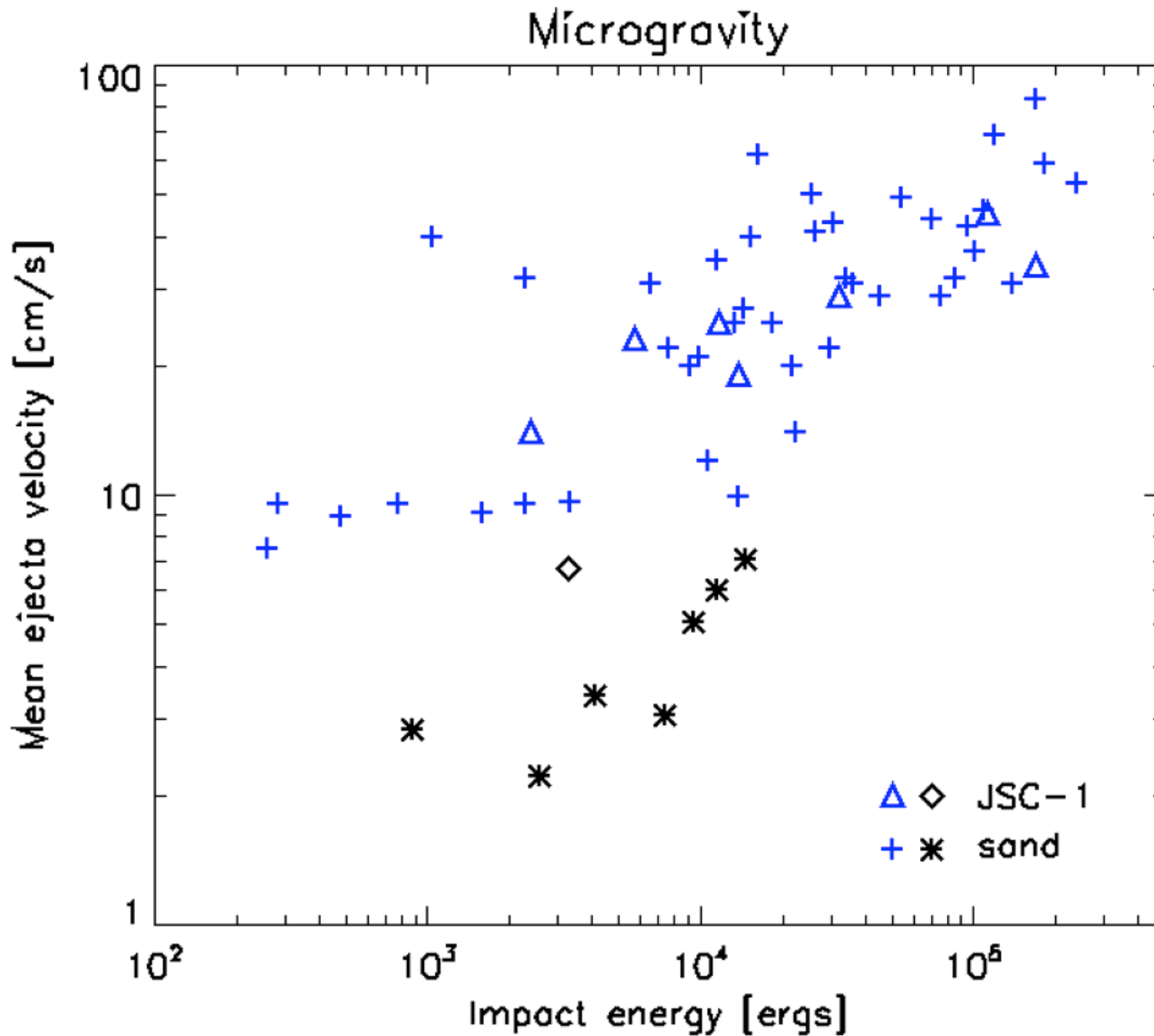

# Data Analysis — Craters

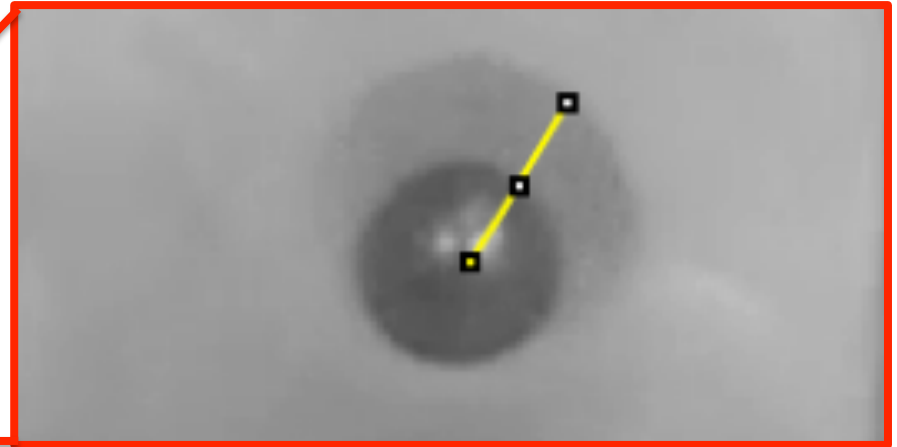
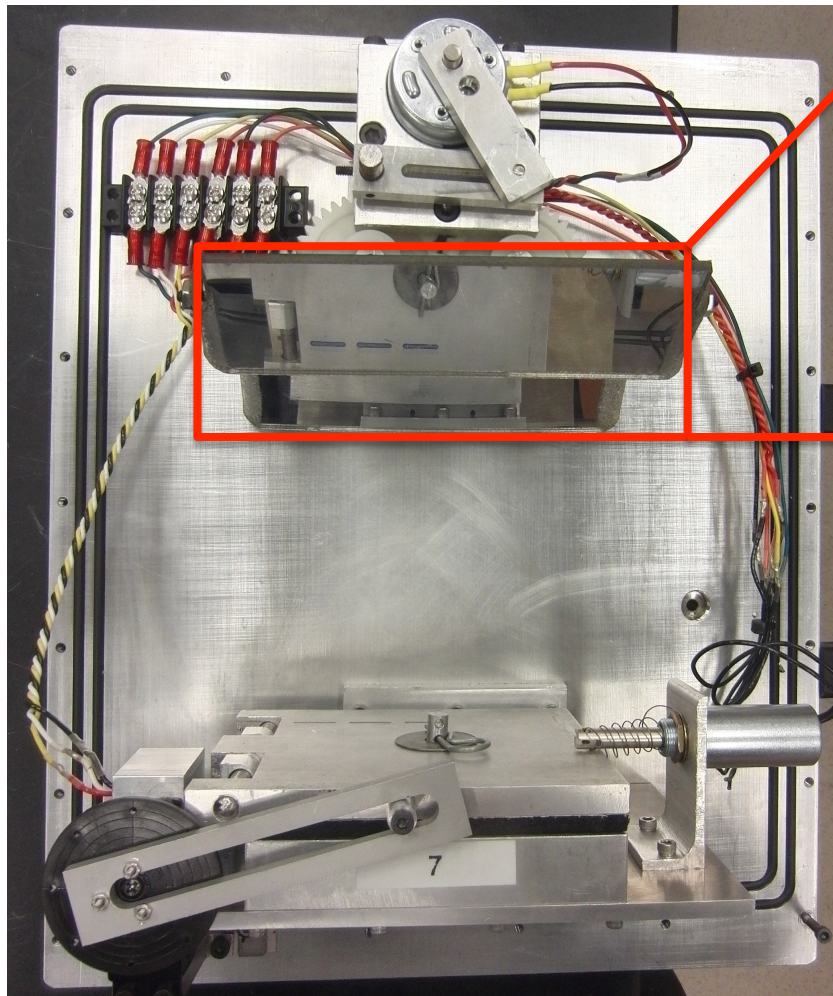

# Results— Crater Opening Speed

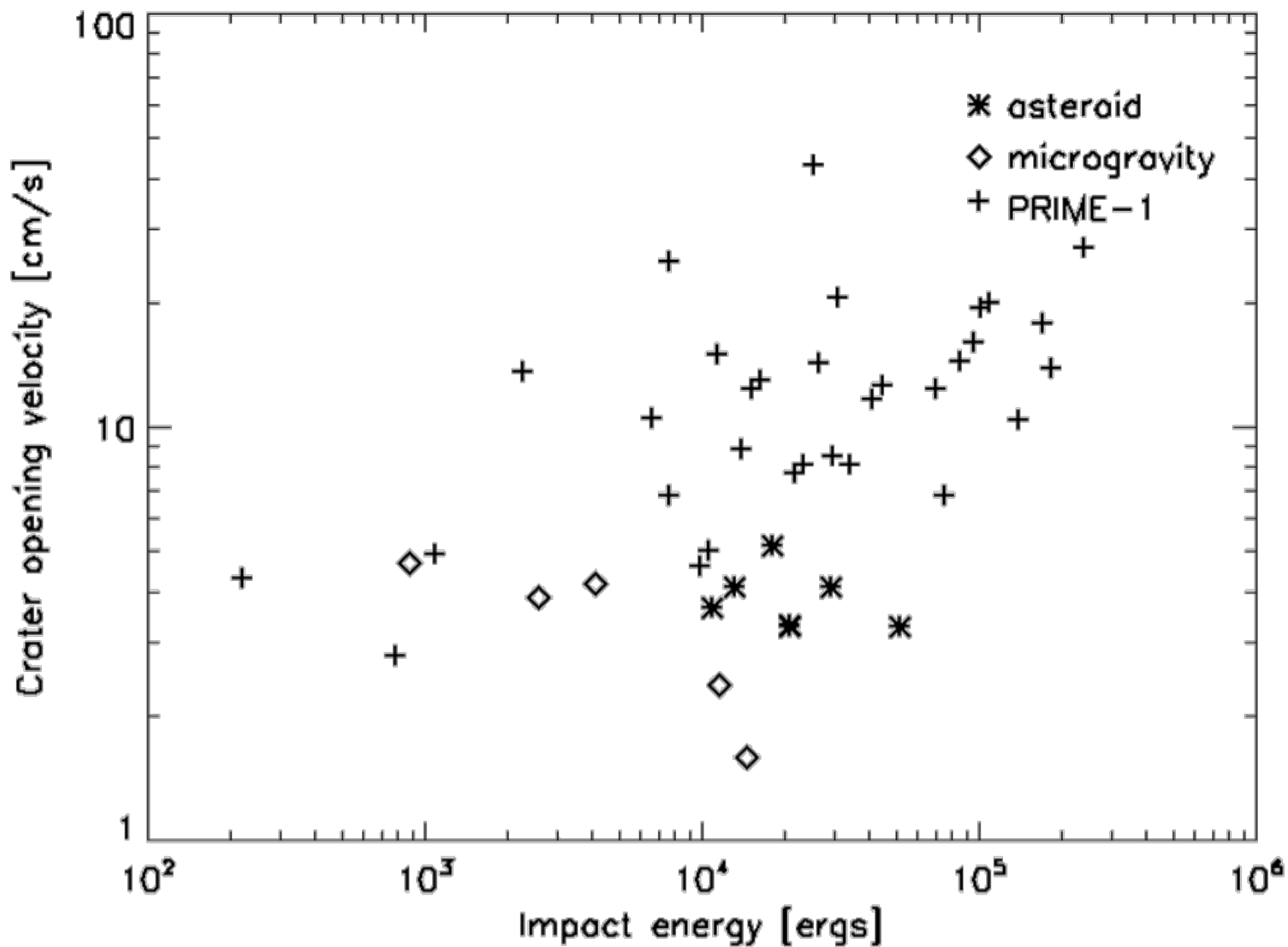

# Outlook — Laboratory Experiments



# Outlook — Laboratory Experiments

- Impact speeds from 20 to 200 cm/s

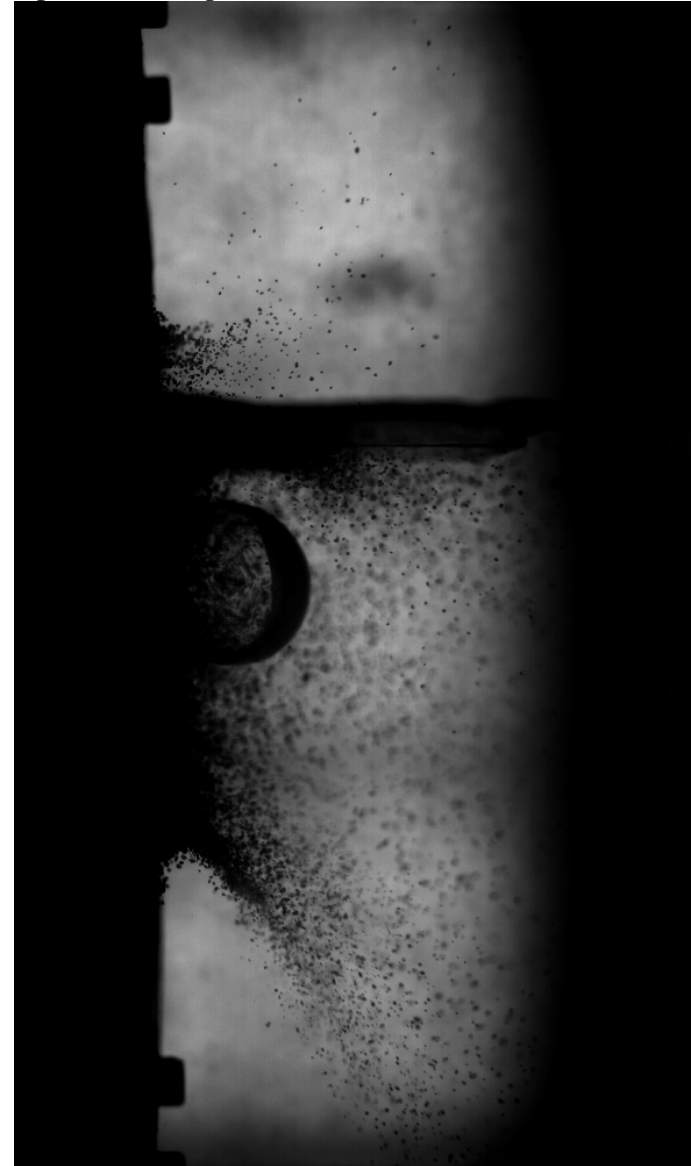
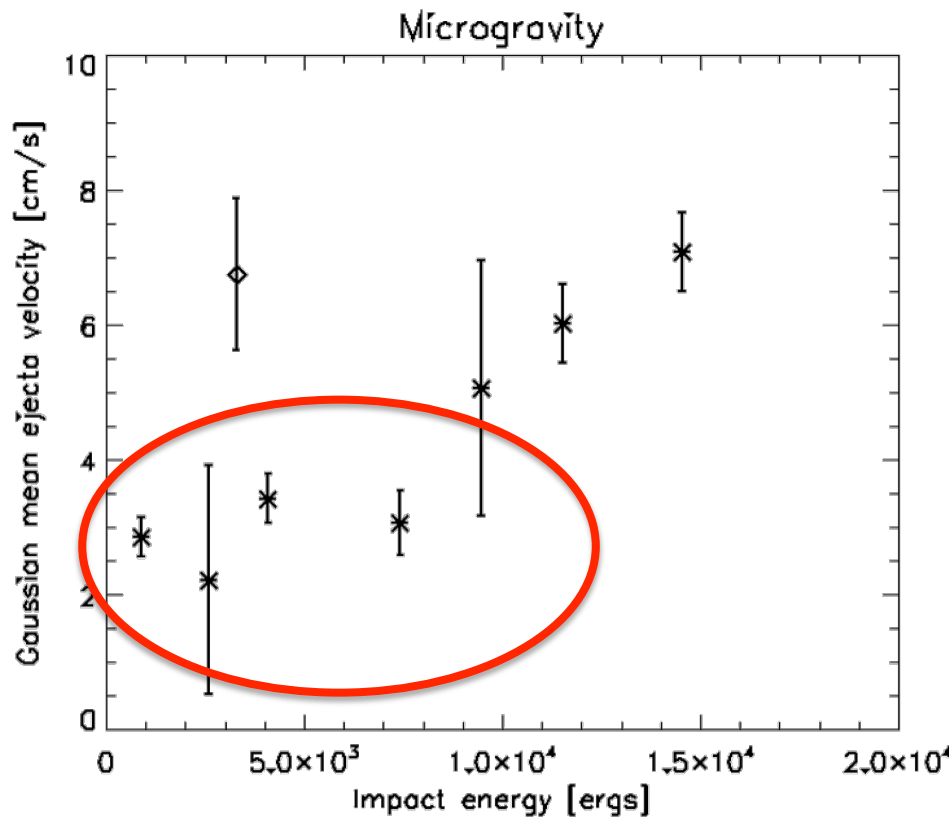

# Outlook — Hardware Development

PRIME-4 selected by NASA Flight Opportunities for development and flight in 2016 with 2.5x greater data capability.

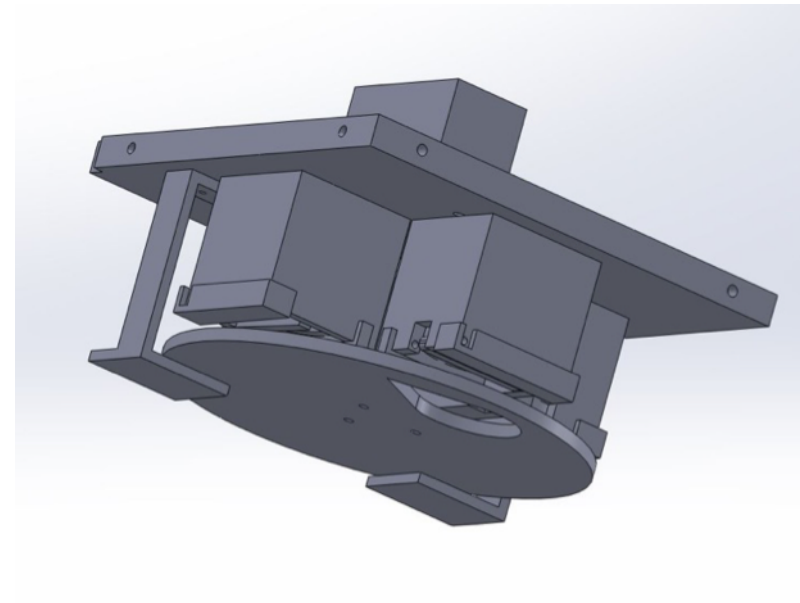
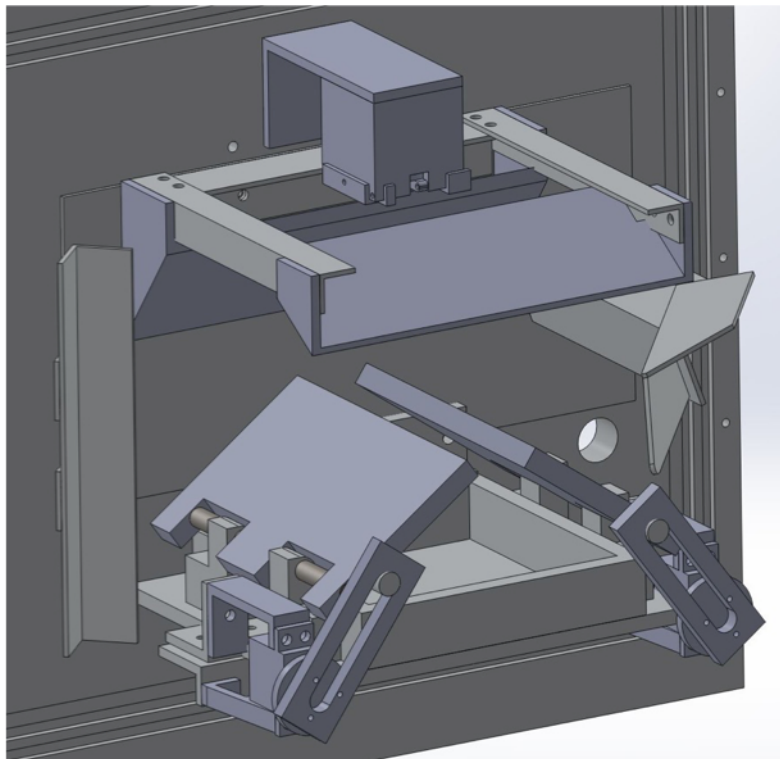

COLLIDE payload with lower impact velocities and cleaner free-fall environment to fly on upcoming suborbital flight on New Shepard (Blue Origin).